



**Countertop Head Unit Repackaging Instructions**

**RMA**

5/10/24

## Countertop Head Unit Repackaging

- Option 1 - Off-The-Shelf Packaging
  - The Bevi countertop head unit can be returned in a generic overbox with adequate interior packaging:
    - Overbox must have dimensions  $\geq 24'' \times 12'' \times 12''$  and should not exceed  $30'' \times 18'' \times 18''$ 
      - An example of an acceptable box is [S-4243](#) from Uline
    - Bubble wrap, filler paper, or some similar material must be used to pack fully around the head unit, and fill all empty volume within the overbox.
    - The box should then be securely taped shut
- Option 2 - Bevi Packaging
  - The Bevi countertop head unit can be returned in its original machine packaging or packaging from a different Bevi head unit.
  - The **original machine packaging** is Bevi part number #720-0155.
  - This box is also orderable via the Bevi Storefront (order p/n **#720-0155**) and will ship as an empty box with custom interior packaging designed for the head unit.

*Note: If returning a full countertop machine (head unit + chiller), please refer to slide 5*

## Option 1 - OTS Packaging

1. Use bubble wrap (or similar material) to line the interior base and sides of the box.
2. Place the head unit kit on the bubble wrap liner with the screen facing up.
3. Use bubble wrap (or similar material) to cover the front of the head unit, ensuring adequate coverage over the screen.
4. Use additional bubble wrap as needed to fill any voids within the box pack.
5. Tape the outer box shut.



## Option 2 - Bevi Packaging

1. Place 1x of the rectangular flat pack (item 3) in the base of the box (item 1).
2. Place the countertop unit on its back within the box and on top of the flat pack.
3. Place the interior wrap-around packaging (item 2) around the head unit.
  - a. Ensure the black insulated water lines and flavor lines are fed through the cutout in the interior packaging.
  - b. Form a tight loop containing the insulated water lines, flavor lines, ethernet cable, and power cable.
  - c. Secure the loop between the interior packaging and edge of box.
4. Tape the bagged drip tray assembly under the dispense area.
5. Place 1x of the rectangular flat pack (item 3) on top of the packed head unit.
6. Tape the outer box shut.

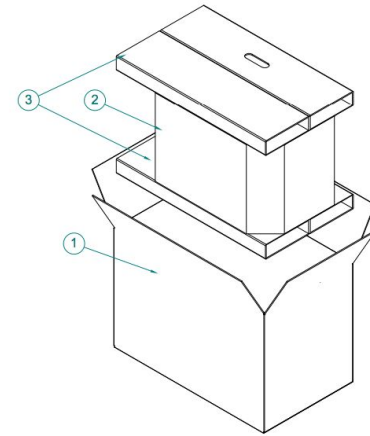
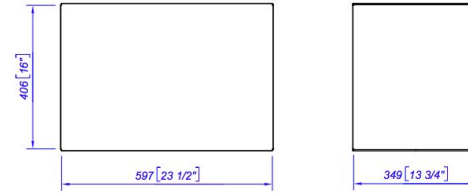

## Full Countertop Machine Return (head unit + chiller)

- 1) Ensure that the Bevi machine and chiller are properly decommissioned
  - a) Refer to the guide from [partners.bevi.co](https://partners.bevi.co) for complete [countertop decommission instructions](#).
- 2) Package the countertop head unit per instructions on pages 2-4.
- 3) Package the chiller per the [Chiller Return Instructions guide](#).
- 4) Secure both boxes to a shipping pallet using straps and/or shrink wrap.
- 5) Ship via LTL services.

# Countertop Shipping Specifications

## Shipping Specifications - Head Unit Only

- 16" x 24" x 14"
- 25 lb
- Country of Origin = USA
- Ship via parcel services

## Specification - Full Countertop Machine (Head Unit with Chiller)

- 48" W x 40" L x 18" H (W and L dimensions are determined by the pallet size and will change based off the pallet that is used)
- 150 lb (This includes 45 lb for a standard 48 x 40 pallet. Other pallets may have different weights.)
- Freight Class = 125
- Country of Origin = USA
- Ship via LTL services
- DO NOT STACK ANYTHING ON TOP OF THE PACKAGED PALLET



**Questions?**

**Please reach out to [support@bevi.co](mailto:support@bevi.co)**

