

How to Swap Flavor & Enhancement Boxes

Countertop Guide



This document will show you how to swap flavors or enhancements in the Countertop.

1. Open Service Panel

1. Enter the Service Panel by tapping the Service icon in the top left corner of the dispense screen.
2. Then tap Start Service.

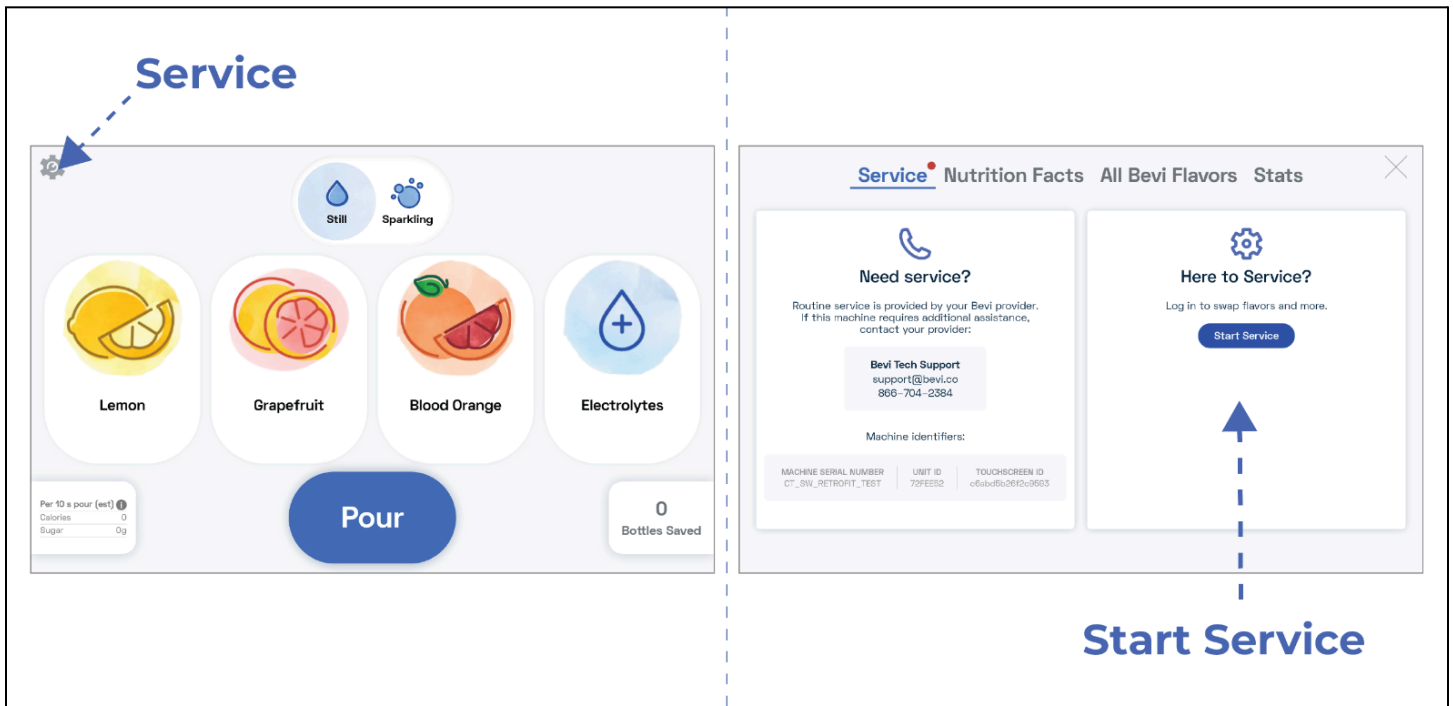

3. Enter PIN, **1986** to access the Service Panel.
4. Review the Service Panel to see what flavors are out or expired, highlighted in red.

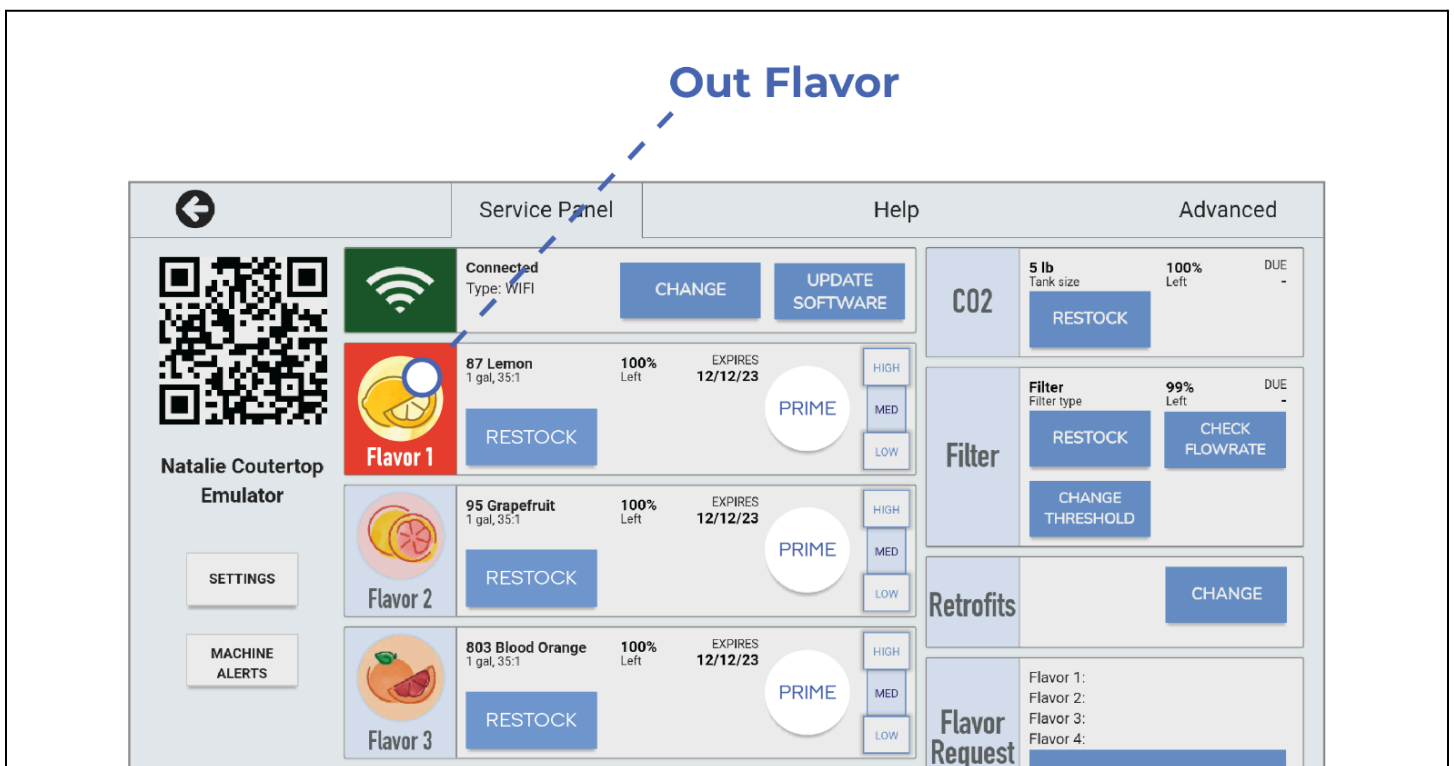

2. Open Cabinet Doors

Open the cabinet door and locate the flavor box (BiB) that needs to be replaced, as shown in Service Panel.

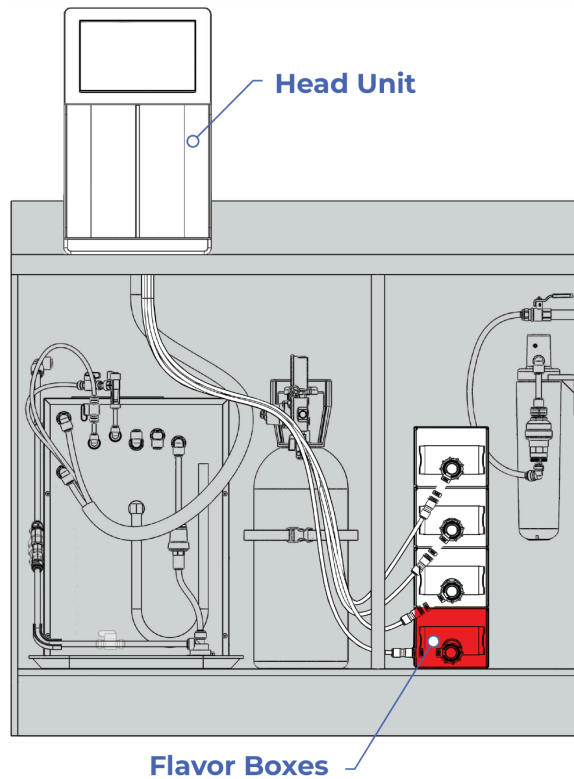

3. Disconnect the Flavor Box

BLUE CONNECTORS:

- Disconnect the **blue connector** from the **flavor box** by rotating it counterclockwise until it is free.

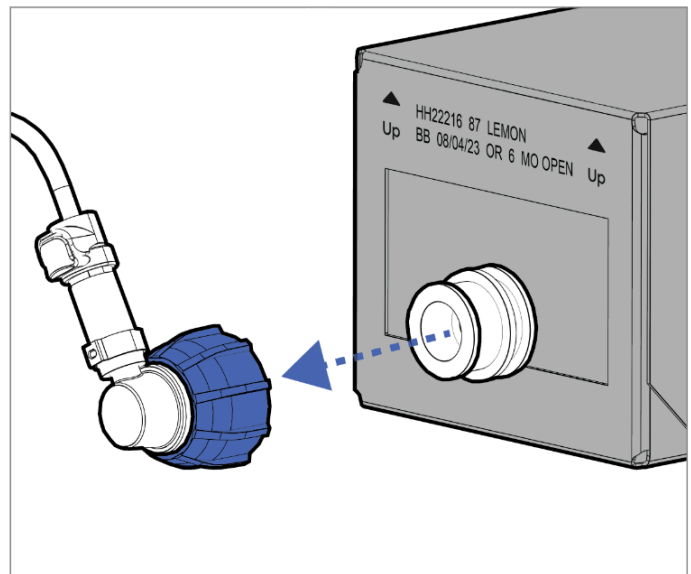
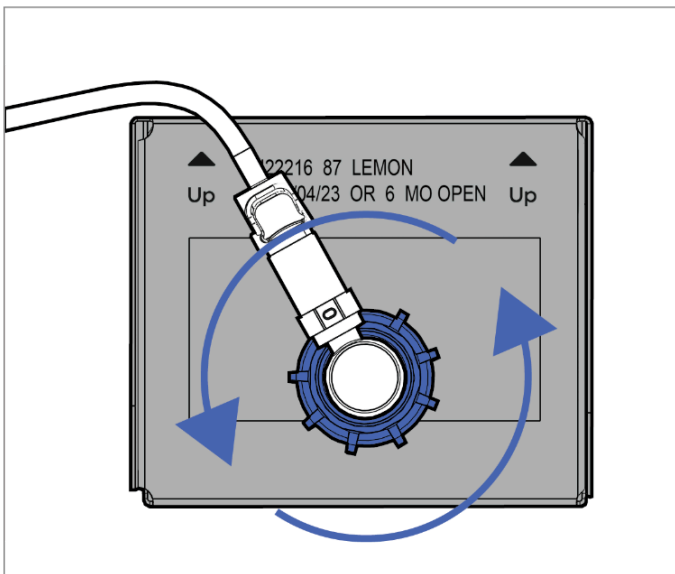

GRAY CONNECTORS:

- Disconnect the a Gray connector by pulling on the tubing while pushing on the gray tabs.
- Once the connector is open, slide it down to disengage from the box.

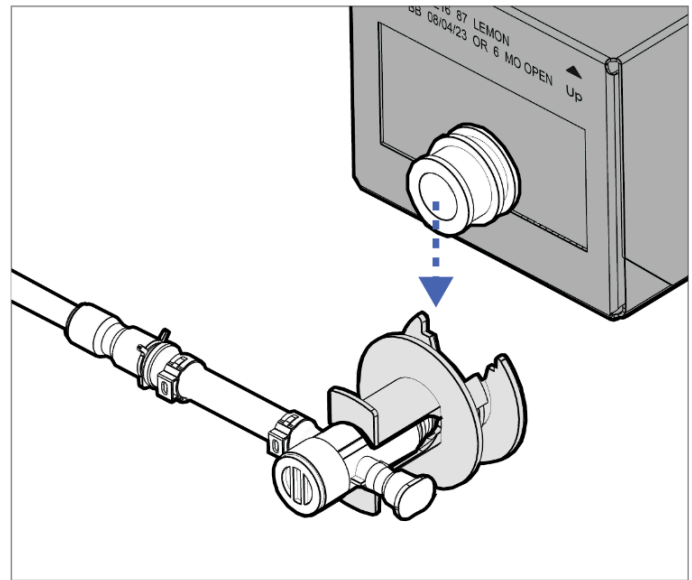
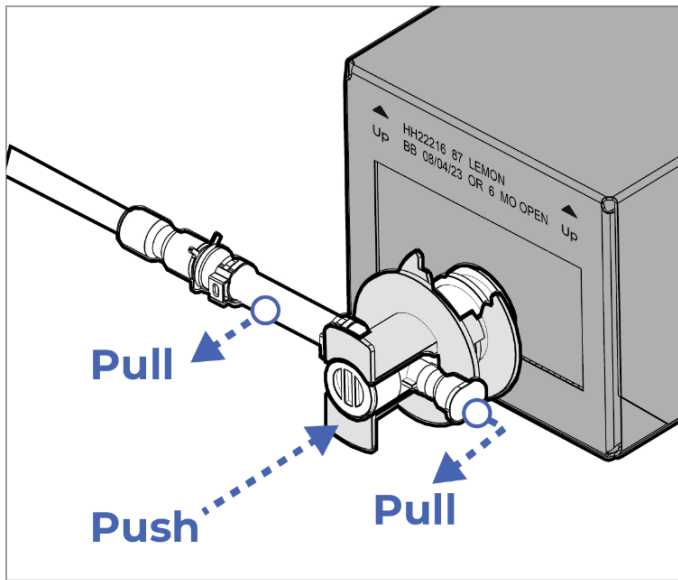

4. Open the new Flavor Box

Break open the center perforation on the flavor box, and open the sides.

- Remove the cap and expose the flavor nozzle.

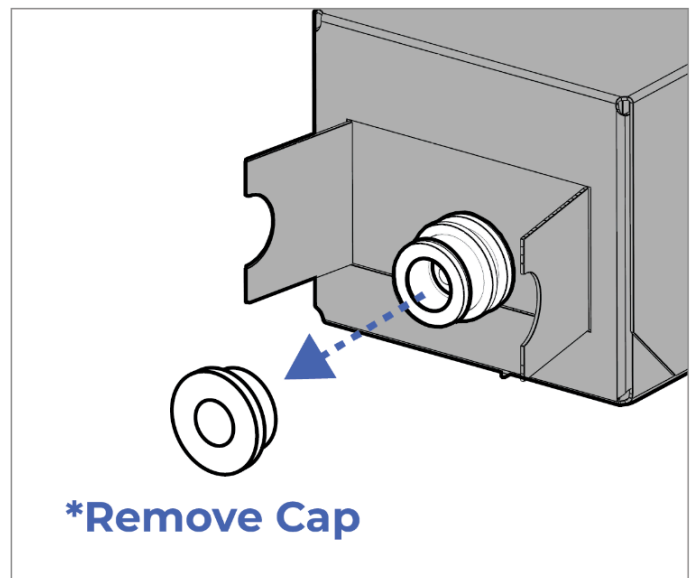
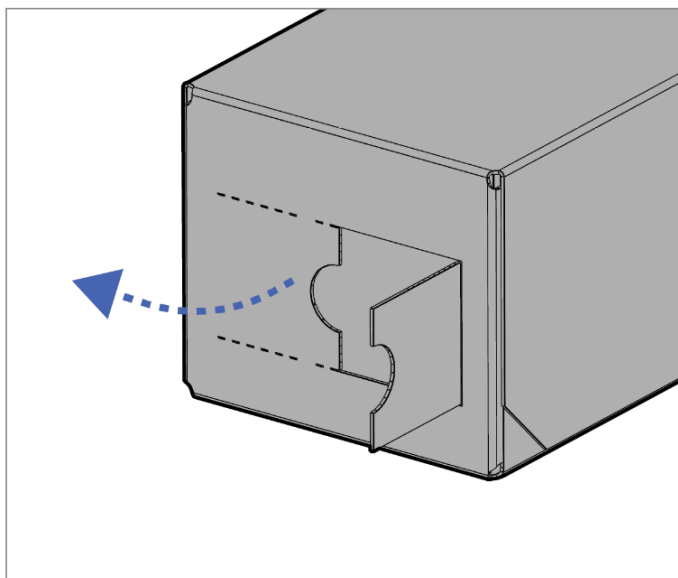

5. Connect the new Flavor Box

Re-attach the blue or gray connector to the nozzle.

BLUE CONNECTORS:

- Ensure the connector is fully seated and not leaking.
- Improper alignment can inhibit flavor from dispensing properly.

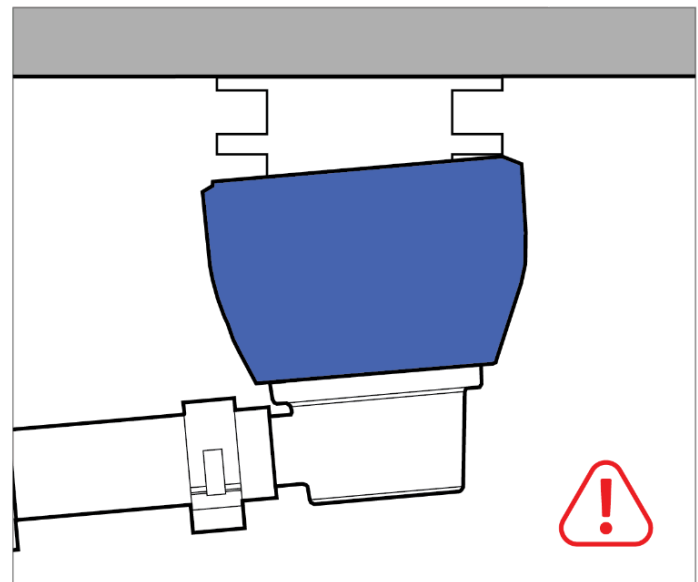
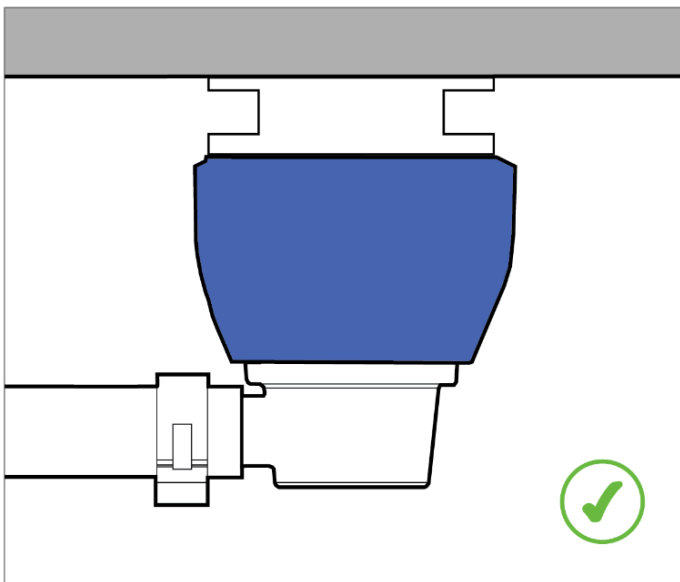
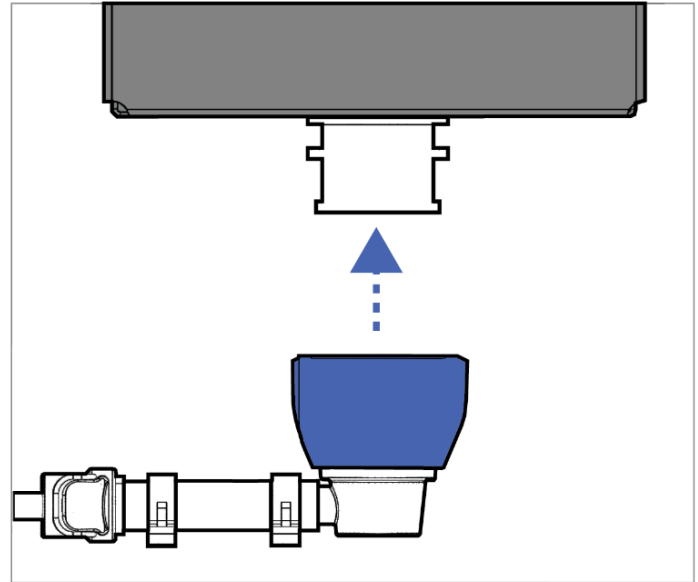
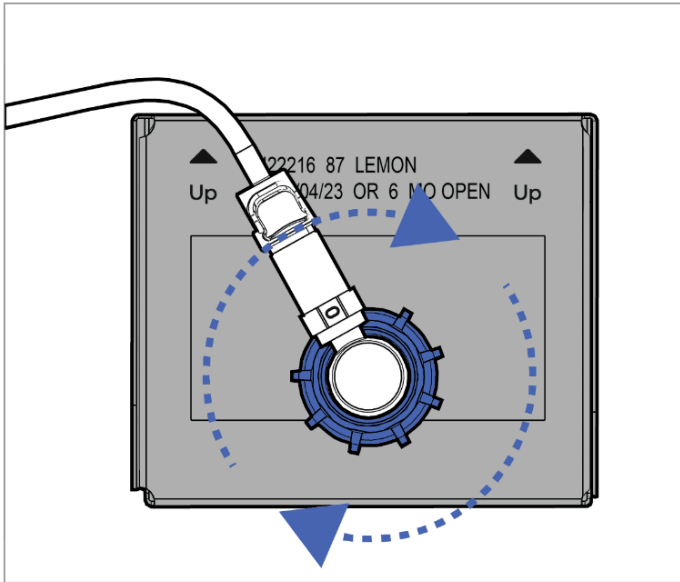

GRAY CONNECTORS:

- Ensure the connector is fully seated and not leaking.

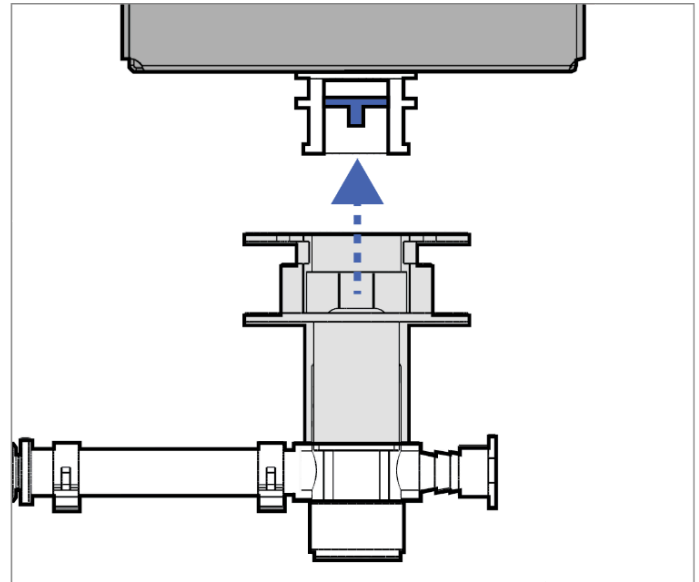
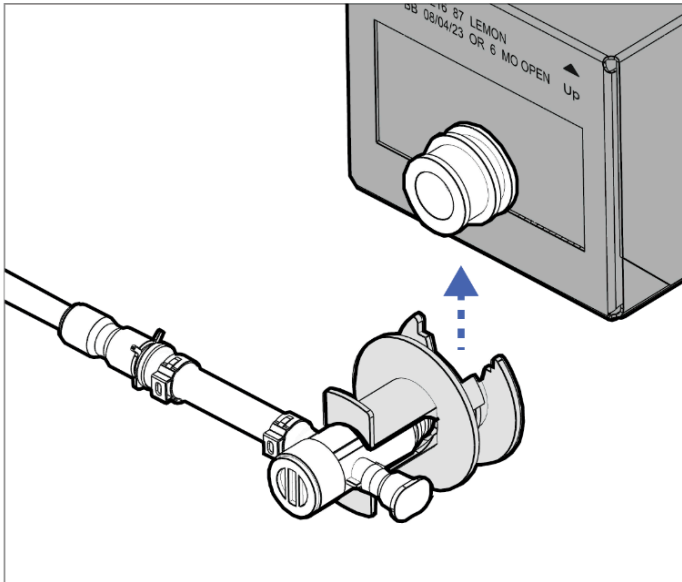

6. Tap the new Flavor's "Restock" button

Enter the new Flavor Number & Best by date, both can be found of the front of the flavor box.

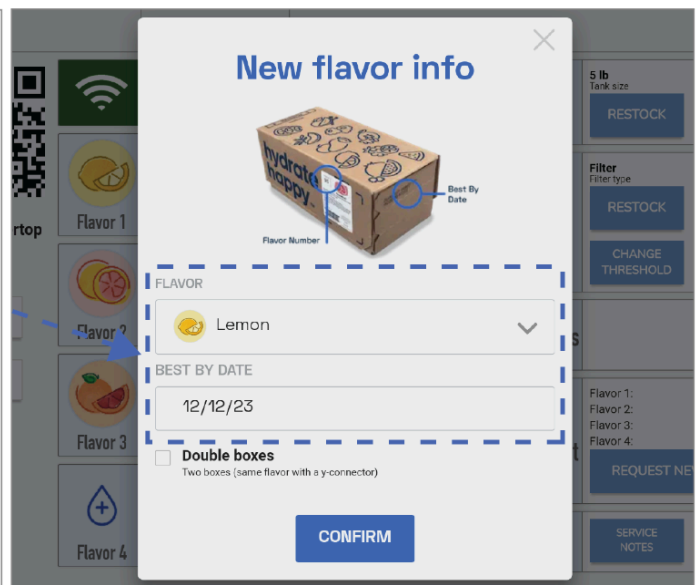
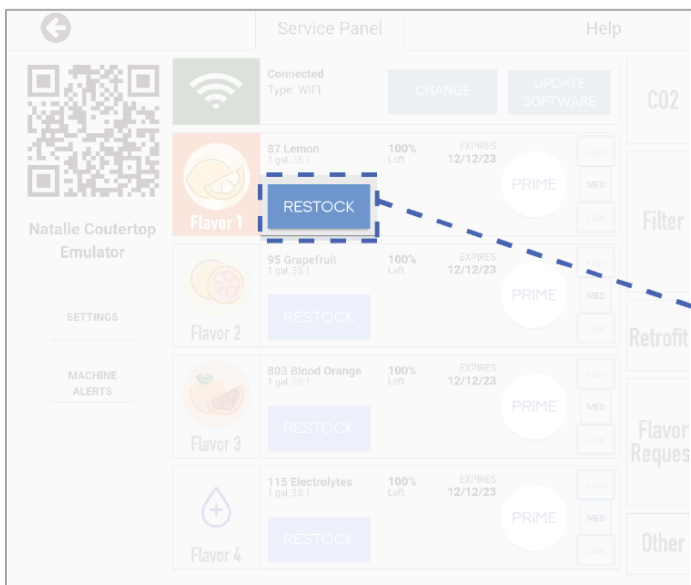

7. Prime

Hold a cup under the nozzle and press and hold the Prime button on screen for 15 seconds.



8. Finish Service

Tap the **Back Arrow** to finish service and return to the dispense screen.

