

Installation Guide

Countertop 1.5 Machine



In this document, you will find a step-by-step guide to install the Bevi Countertop 1.5 machine.

Revision History

Revision	Date	Detail	Authors	Reviewers
Rev 01	Feb 26, 2025	PV Release	TF	EB, SG, DS, MG
Rev 02	April 2, 2025	MP Release	TF	AJ, AF
Rev 03	Sept. 18, 2025	Feedback based update	AF	TF, RC
Rev 04	Mar. 6, 2026	Image corrections and Inlet flushing	AF	RC, PK, AH

**** Area left blank ****

COMPACT CHILLER VENTILATION

⚠ DO NOT place the compact chiller directly on the cabinet floor!

IMPORTANT: The compact chiller **requires** its lower ventilation grate to remain clear and properly vented, per the standard installation instructions. The compact chiller will malfunction if its grate is blocked.

Use one of the *approved alternative ventilation methods* if the cabinet can't support the standard ventilation requirements. Contact Bevi Technical Services to confirm approved solutions at 866-704-2384 (BEVI).

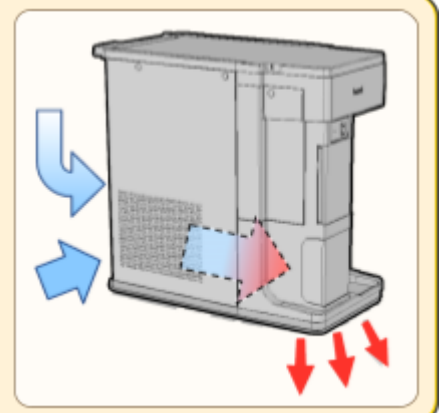

CT 1.5 Quick Start Guide

1. Ensure water and power are shut off before starting the installation. **DO NOT** open water/CO2 valves until prompted by the install wizard.
2. Check safety (pg 3) and Pre-Installation requirements (pg 9)
 - Supply pressure: 40-80 psi, Min. Flow Rate 4 Lpm (1.05 gpm), dedicated 3/8" source plumbing line 140+ psi Rating.
3. Drill countertop hole (template on pg 15).
4. Cut/Drill toe kick ventilation hole (templates on pg 20, 21). **Correct ventilation is required.** Clean Cabinet and counter top to prepare for install.
5. Install CO2 tank bracket and strap into cabinet (template on pg 24). Install CO2 Regulator on the tank. **DO NOT** open CO2 valve until prompted by install wizard.
6. Feed the trunkline from the head unit through the countertop hole.
7. Lift the Head Unit upright and into place. Threaded coupler can be unscrewed from the head unit; reinstall it after the Head Unit is in place. Threaded coupler is sharp: gloves or cloth recommended when handling.
8. Secure Head Unit by threading the supplied split nut onto the threaded coupler. Hand tighten until flush to the underside of the mounting surface.
9. With the chiller outside the cabinet, install inlet water, still, and sparkling lines into the back of the chiller. Flush the supply water line until it is free of debris, before connecting to the chiller. **Ensure all lines are fully pushed in or you will have water leaks.**
10. Connect Head Unit power and data cables, as well as AC power cord into the chiller. **DO NOT** turn power on or off unless all lines are connected.
11. Connect CO2 line from regulator into the top of the chiller (under CO2 access panel, see pg 34). Reinstall access panel after connection is made. **Connector latch should face upward.**
12. Double check all power, data, and water connections. **Check water line connection, there should be no water present around the connection.**
13. Place the chiller inside the cabinet, ensuring alignment with the ventilation hole from step 4. Locator tabs at the bottom of the chiller will help align. **Proper ventilation out of the cabinet is REQUIRED.**
14. Install all flavor connectors, first to the flavor lines, and then to the Flavor Boxes (BiBs).
15. Connect the AC power cord to power outlet. Turn on the power switch on the front of the chiller and follow the on-screen install wizard.

Introduction

SAFETY NOTICE

- **CAUTION:** No user servicing/serviceable parts.
- This appliance must be properly installed on a GFCI protected circuit.
- Maximum water inlet supply pressure: 80 PSI (0.55 MPa).
- This appliance is not intended for use by persons (including children) with reduced physical, sensory or mental capabilities, or lack of experience and knowledge, unless they have been given supervision or instruction concerning use of the appliance by a person responsible for their safety.
- Children should be supervised to ensure that they do not play with the appliance.
- Appliance is only to be installed in locations where it can be overseen by trained personnel.
- The appliance must not be cleaned by a water jet.
- For indoor use only. 10–32°C (50–90°F).
- Appliances shall not be installed in an area where a water jet could be used.
- Do not store explosive substances such as aerosol cans with a flammable propellant near the appliance.
- This appliance is climatic class 0: 20°C (68°F), 50% RH, 9.3°C dew point, 7.3 g/kg water vapor mass in dry air.
- Water pipe connections and fixtures directly connected to a potable water supply shall be sized, installed, and maintained in accordance with federal, state, and local codes.

FCC / ISED

- Changes or modifications not expressly approved by Bevi could void the user's authority to operate the equipment.
- This device complies with Part 15 of the FCC Rules. Operation is subject to the following two conditions: (1) this device may not cause harmful interference, and (2) this device must accept any interference received, including interference that may cause undesired operation
- This equipment has been tested and found to comply with the limits for a Class A digital device, pursuant to part 15 of the FCC Rules. These limits are designed to provide reasonable protection against harmful interference when the equipment is operated in a commercial environment. This equipment generates, uses, and can radiate radio frequency energy and, if not installed and used in accordance with the instruction manual, may cause harmful interference to radio communications. Operation of this equipment in a residential area is likely to cause harmful interference in which case the user will be required to correct the interference at his own expense.
- This device contains license-exempt transmitter(s)/receiver(s) that comply with Innovation, Science and Economic Development Canada's license-exempt RSS(s). Operation is subject to the following two conditions: (1) this device may not cause interference, and (2) this device must accept any interference, including interference that may cause undesired operation of the device.
- Cet appareil contient des émetteurs/récepteurs exempts de licence qui sont conformes aux RSS sans licence d'Innovation, Sciences et Développement économique Canada. L'exploitation est autorisée aux deux conditions suivantes : (1) l'appareil ne doit pas produire de brouillage, et (2) l'appareil doit accepter tout brouillage radioélectrique subi, même si le brouillage est susceptible d'en compromettre le fonctionnement.
- This equipment complies with FCC and ISED radiation exposure limits set forth for an uncontrolled environment. This equipment should be installed and operated with a minimum distance of 20cm between the radiator and your body. This transmitter must not be co-located or operating in conjunction with any other antenna or transmitter.

TABLE OF CONTENTS

Introduction.....	3
SAFETY NOTICE.....	3
FCC / ISED.....	4
TABLE OF CONTENTS.....	5
TOOLS AND MATERIALS.....	6
MACHINE OVERVIEW.....	7
WATER CONNECTIONS OVERVIEW.....	8
Pre-Installation Requirements.....	9
CABINET CONFIGURATIONS.....	10
1. Single Cabinet.....	10
2. Two Cabinets.....	10
VENTILATION.....	12
Standard Ventilation.....	12
ABOVE COUNTER.....	13
(Optional) Alternate ADA Installation.....	13
Onsite Installation.....	16
1. Confirm Cabinet Layout.....	16
2. Cut Ventilation (Required).....	17
3. CO2 Tank Setup.....	21
4. Clean Countertop and Cabinets.....	26
5. Head Unit Setup.....	27
6. Chiller Setup.....	29
7. Flavor Setup.....	34
8. Complete Setup on Screen.....	35
9. Before You Leave.....	36

TOOLS AND MATERIALS

Bring the following tools and materials to install the Countertop 1.5 Unit.

- HF20-I filter
- Tubing and fittings
 - 3/8" flexible HDPE tubing
 - 1 x 3/8" Push-to-Connect shutoff valve
- Safety glasses
- Cordless drill
- Philips head screwdriver - Size PH02
- Flathead screwdriver
- Hole-saw bits
 - 1-1/4" for countertop hole (if not pre-drilled), diamond hole saw for stone countertops
 - 1-1/2" for ventilation holes
 - OR jigsaw with blade
- Drill bits
 - 1/16" for CO2 strap brackets
- PSI pressure gauge capable of reading up to 120 PSI
- Flow meter or graduated cylinder to measure flow rate
- Tape measure
- Painters tape or masking tape
- Vacuum
- 1 x gallon bucket
- Paper towels
- Trashbags
- Adjustable wrench, adjustable to 1-1/8" for CO2 tank
- Tube cutter
- Wire cutter, scissors, or box cutter for zip ties and packaging

MACHINE OVERVIEW

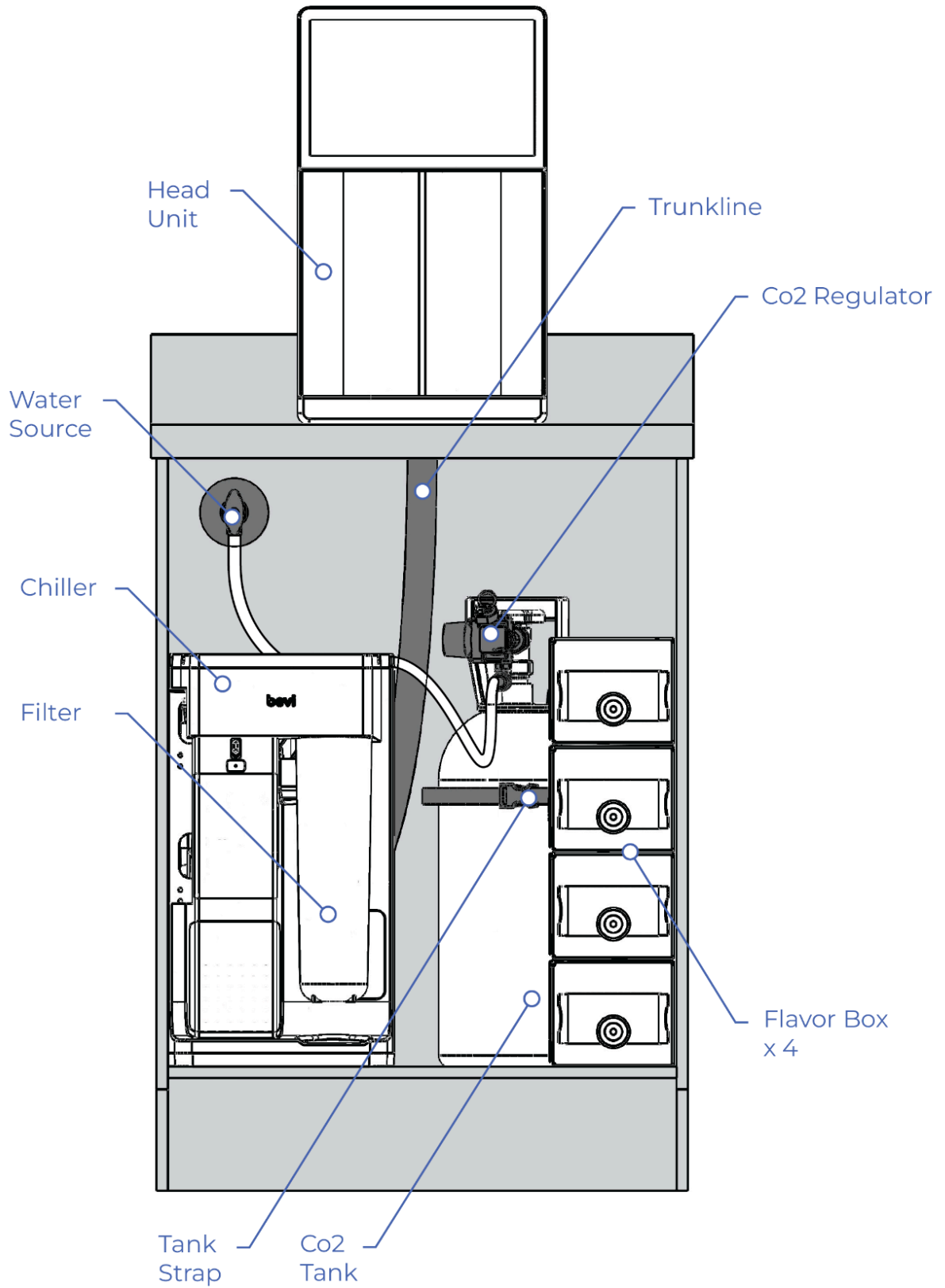

WATER CONNECTIONS OVERVIEW

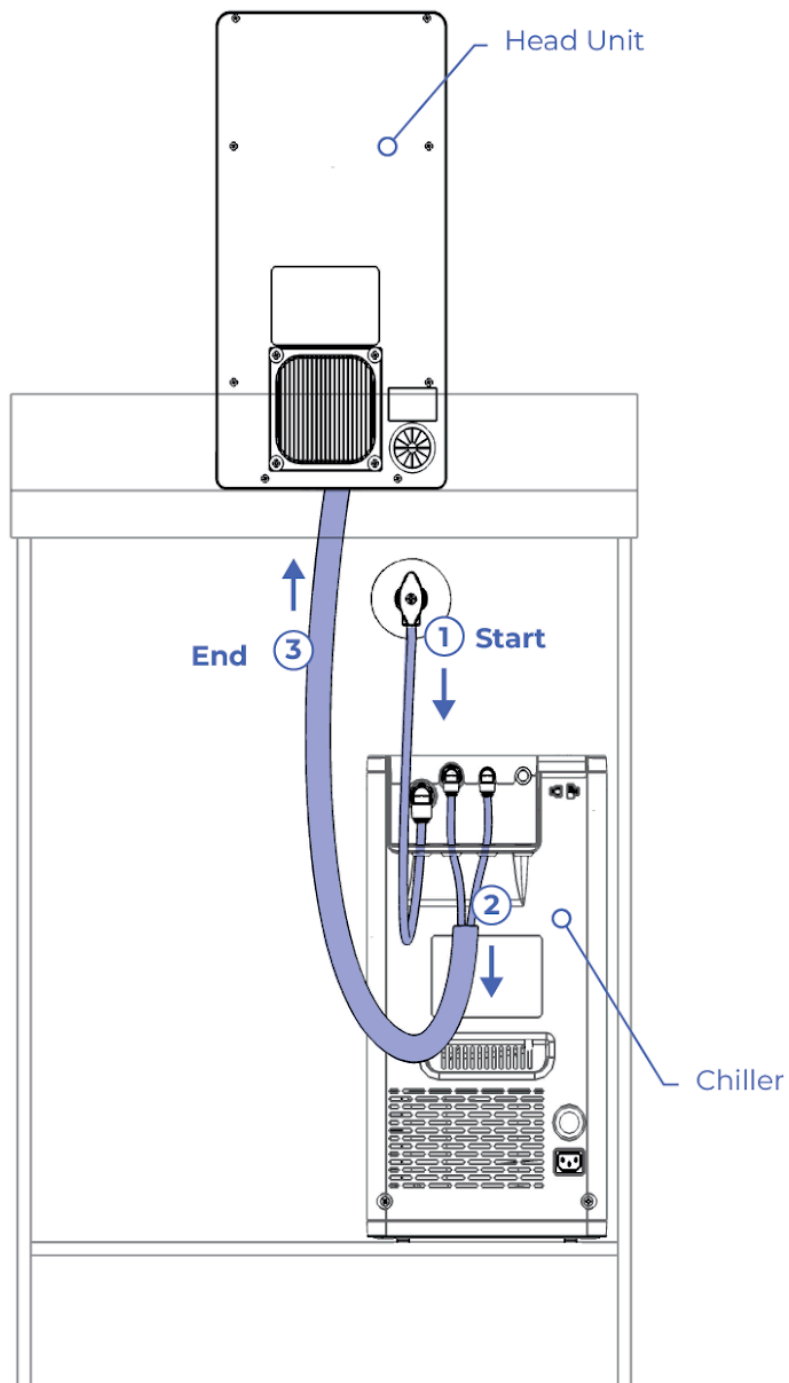

Pre-Installation Requirements

Countertop 1.5 machines

Confirm the following requirements are met prior to starting installation!

Water Source

- Dedicated 3/8" plumbing line, rated for a minimum of 140 psi
- Minimum supply pressure of **40 PSI and 4 liters per minute [1.05 gpm] flow rate**
- Maximum water inlet supply pressure of **80 PSI**
- **DO NOT** allow a water filter to be used on the water source. If one exists, make sure the water source is tapped upstream of the filter.

Confirm flow rate: Dispense 1 L of water from the water source and time how long it takes to fill. A completion time of 24 seconds or less indicates sufficient flow.

Confirm pressure: Connect a pressure gauge (rated 120+ psi) to the dedicated 3/8" plumbing line. Open the water source, wait until the reading stays steady, then confirm the pressure gauge reads greater than 40 PSI / 3.5 BAR.

Power Source

- 110–120V AC Outlet, 10+ amp circuit breaker (Unit draws ~7 amps)
- Preferred location is **above the counter within 24"** of the Head Unit

Internet Source

Ensure one of the following is available on site:

- Wi-Fi (2.4 or 5 GHz 802.11N Wireless Network)
- Ethernet Connection (RJ-45)
- Cellular Reception

Chiller Upright Storage

The Compact Chiller can be turned on immediately if shipped upright. If it was not shipped upright, it should be stored in an upright position for *at least 24 hours* before powered on.

Ventilation

- Base Cabinet must have a clean and level floor and toe kick for drilling ventilation.
- A 2" deep toe kick overhang **must** be present for 1.5" ventilation holes. A cabinet floor can be built from plywood if no floor or toe kick is present; contact Bevi support for assistance with approved alternative installation methods. **DO NOT SKIP.**
- Ensure that there is 2" clearance behind the chiller and **at least one** of the two sides (left or right) to allow for adequate airflow into the unit. Chiller footprint is 10"W x 19.75"D.

Millwork and Cabinet Space

- Minimum cabinet size of 18" wide, 22" deep, 22" high to accommodate an 10 lb. CO2 tank
- Minimum clear height of 20" between countertop surface and cabinets above
- 1-1/4" (minimum) hole in countertop, located directly above the chiller
- Dedicated under counter and above counter space that complies with space requirements
 - See Cabinet Configurations on following pages.

CABINET CONFIGURATIONS

Ensure the unit can be installed in one of the following cabinet configurations.

Space under the sink can be used if kept clear of cleaning agents, and BiBs (flavor boxes) are stored off the ground.

* Confirm sufficient space if using shelf to stack BiBs. See partners.bevi.co for recommended accessories.

1. Single Cabinet

<p>Minimum Internal Cabinet Dimensions</p> <p>with 5 lb. or 10 lb. CO2 tank:</p> <p>18" WIDE 22" DEEP 22" HIGH</p> <p>with 20 lb CO2 tank</p> <p>18" WIDE 22" DEEP 28" HIGH</p>	<p style="text-align: center;">TOP VIEW (internal dimensions)</p> <p style="text-align: center;">18" WIDE</p>	<p>Chiller</p> <p>CO2</p> <p>Flavors</p>
--	--	--

2. Two Cabinets

<p>Cabinets 1 and 2</p> <p>Minimum Internal Cabinet Dimensions</p> <p>12" WIDE 22" DEEP 22" HIGH</p> <p>* Cabinets must be side-by-side</p>	<p style="text-align: center;">TOP VIEW (internal dimensions)</p> <p style="text-align: center;">12" WIDE 12" WIDE</p>	<p>Chiller</p> <p>CO2</p> <p>Flavors</p>
---	--	--

Remove Drawers (if necessary)

1. Remove drawers

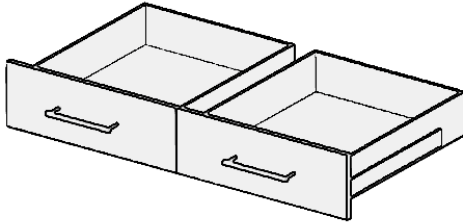

2. Apply false drawers

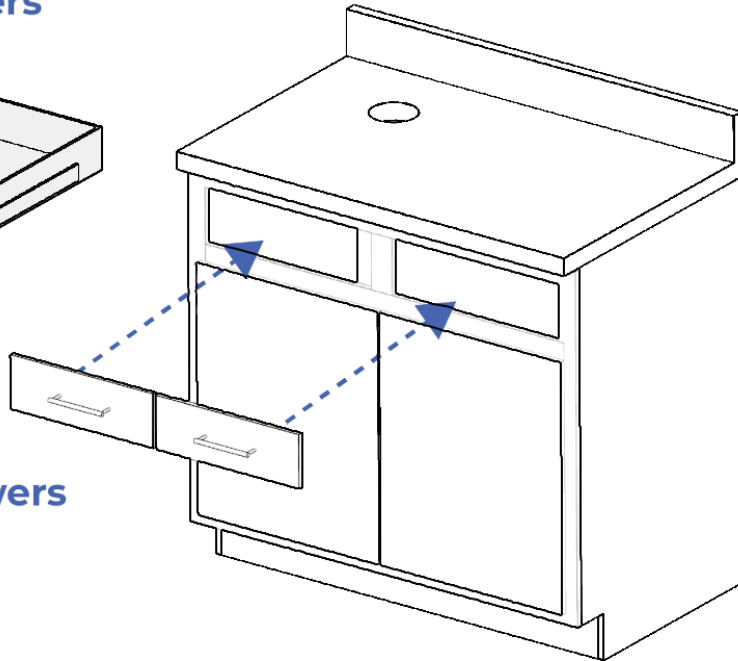

If the cabinet has drawers, work with the customer to remove them and apply false drawer covers.

COMPACT CHILLER VENTILATION • ⚠️ **DO NOT** place the compact chiller directly on the cabinet floor!

IMPORTANT: The compact chiller **requires** its lower ventilation grate to remain clear and properly vented, per the standard installation instructions. The compact chiller will malfunction if its grate is blocked.

Use one of the *approved alternative ventilation methods* if the cabinet can't support the standard ventilation requirements. Contact Bevi Technical Services to confirm approved solutions at 866-704-2384 (BEVI).

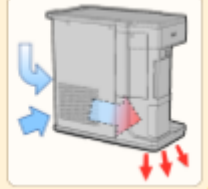

VENTILATION

Confirm that the following ventilation method can work in the available cabinets.

PROPER VENTILATION IS CRITICAL! Without proper ventilation the chiller experiences serious performance problems and can be damaged.

Standard Installation: A 2" deep toe kick overhang **must** be present for the 1.5" ventilation holes.

Alternate Conditions: If no toe kick or cabinet base is present, contact Bevi support for approved installation solutions.

Standard Ventilation

To ensure proper ventilation, cabinets **require** a toe kick with a minimum depth of 2".

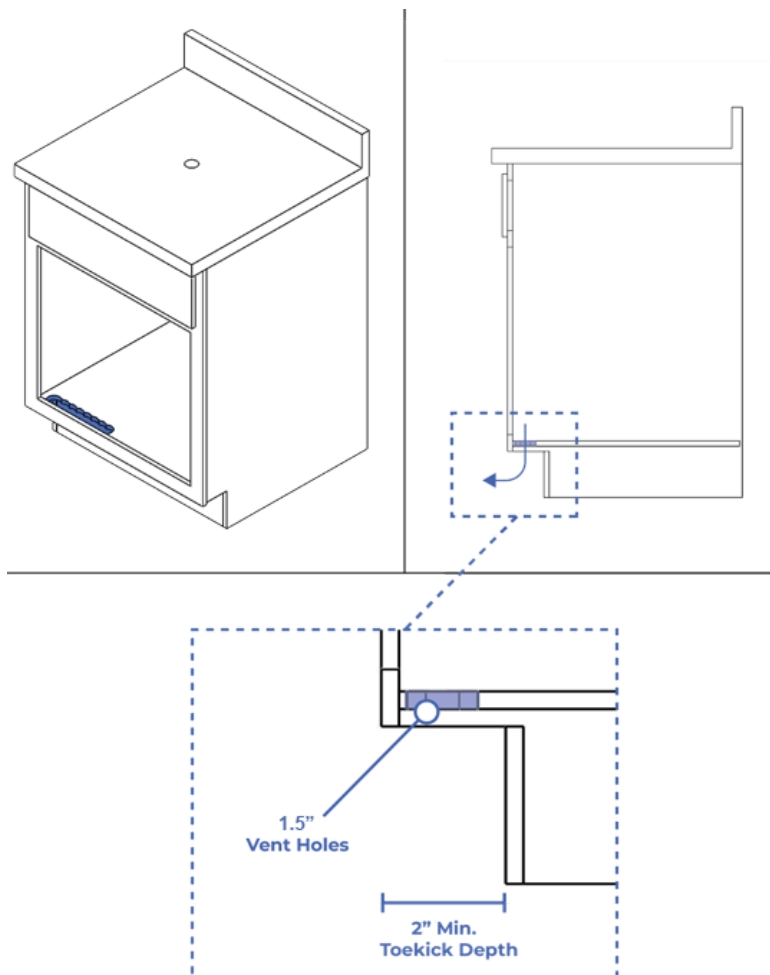

ABOVE COUNTER

Use the Head Unit Hole Template on the next page to ensure appropriate clearance for the Head Unit

1. Ensure a **minimum of 5"** of clearance from the back of the Head Unit to the backsplash.
2. Ensure **1"** of clearance on either side of the Head Unit. This is necessary for proper ventilation.
3. Ensure no shelves or cabinets are below **20"** from the top of the countertop mounting surface, so that the head unit will fit beneath the shelves or cabinets that may be above it.
4. Confirm the final position of the Head Unit with the customer prior to drilling the countertop hole.

(Optional) Alternate ADA Installation:

To comply with ADA reach requirements, these two conditions must be met:

1. The top surface of the countertop **does not exceed 30" from the floor**.
2. Drill the **center** of the mounting hole **9" from the front edge** of the countertop surface. This will align the Head Unit flush with the front edge of the countertop surface.

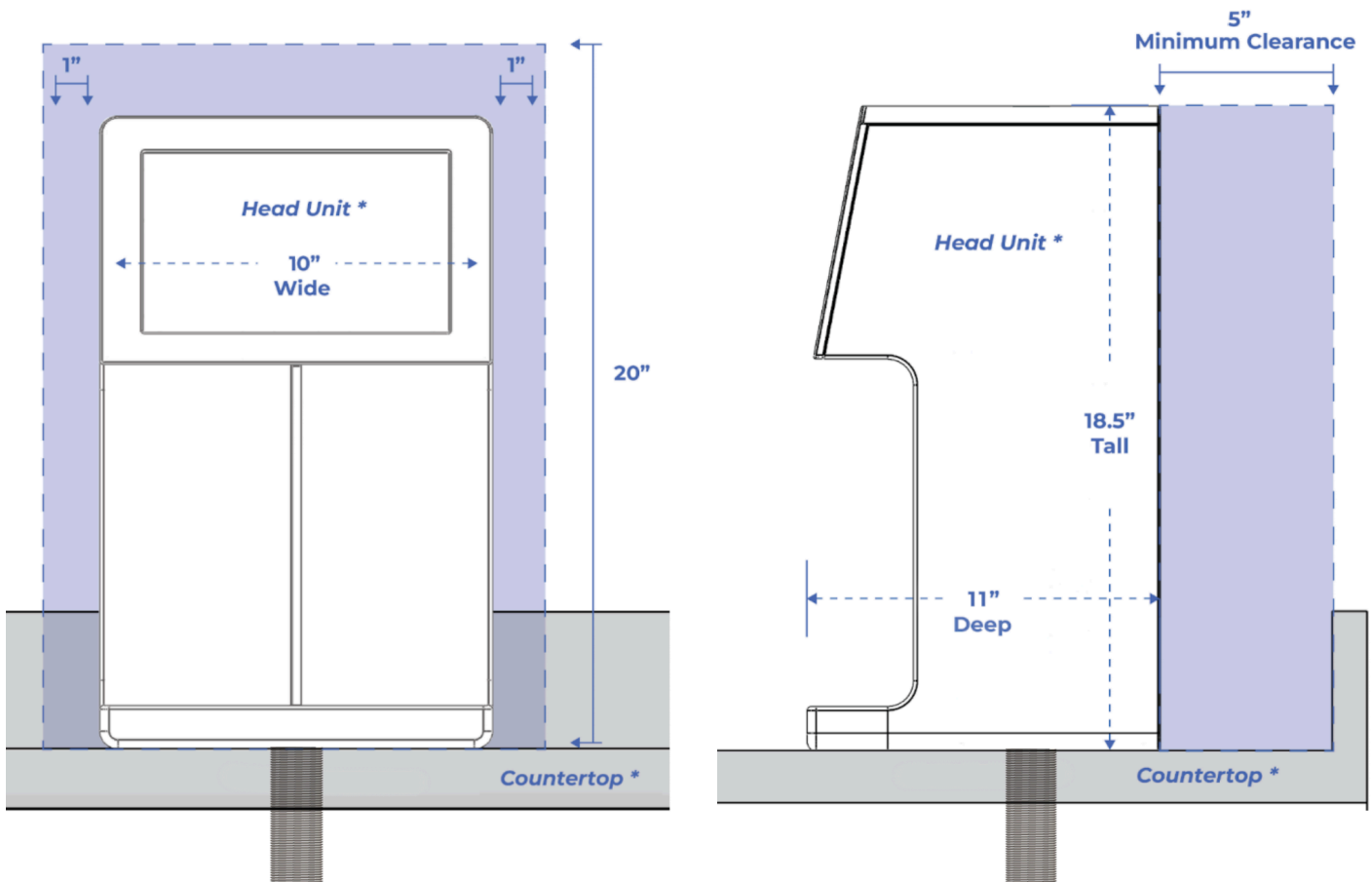

Head Unit Countertop Hole Template

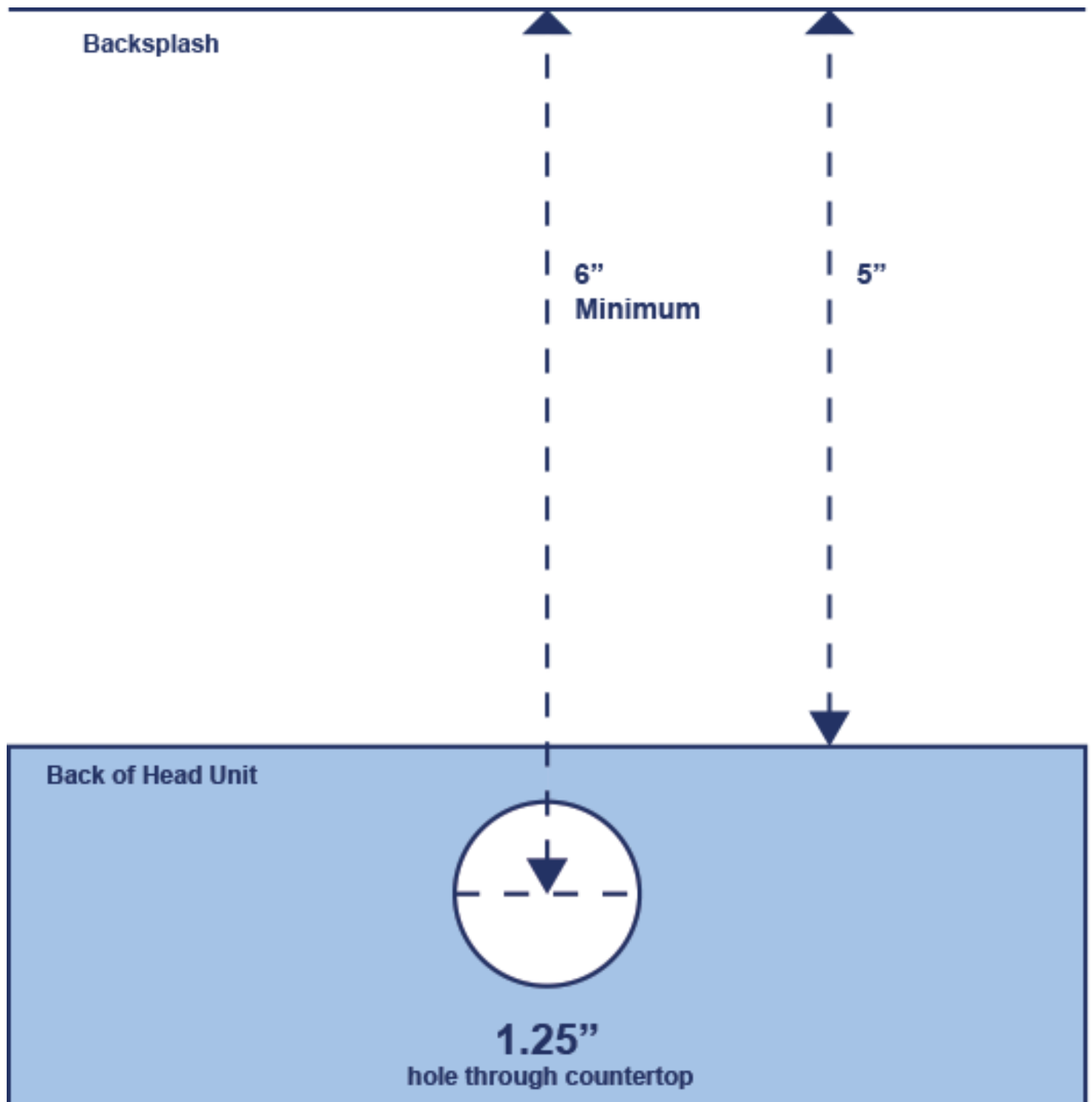

- For reference, the Head Unit is 10" deep and 11" wide, including the drip tray.
- If the countertop hole size is drilled larger than 1-1/2" in diameter, the adapter plate (included in drip tray packaging) will need to be used to make sure that the split nut can secure the head unit to the countertop.

**** Page left blank for template ****

Onsite Installation

Countertop 1.5 machines

1. Confirm Cabinet Layout

Ensure the selected cabinet layout (see pg. 9-10) works with the available cabinetry before drilling holes.

1. Remove cabinet doors for easier access while working.
2. Place the Chiller Vent Hole Template in the cabinet, and use it to visually confirm the chiller will fit.
3. Ensure that there is 2" clearance on at least the back and one of the two sides (left or right) to allow for adequate airflow into the unit.

Check Chiller Location and Toe Kick

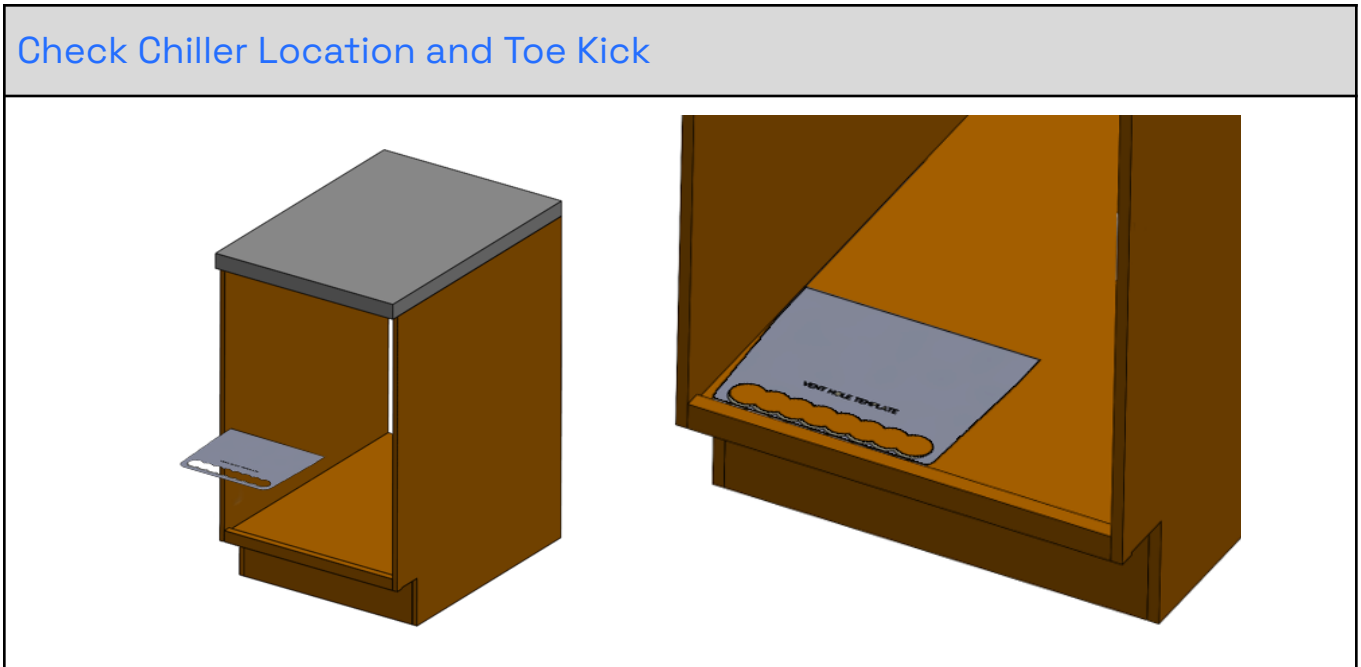

COMPACT CHILLER VENTILATION

⚠ DO NOT place the compact chiller directly on the cabinet floor!

IMPORTANT: The compact chiller **requires** its lower ventilation grate to remain clear and properly vented, per the standard installation instructions. The compact chiller will malfunction if its grate is blocked.

Use one of the *approved alternative ventilation methods* if the cabinet can't support the standard ventilation requirements. Contact Bevi Technical Services to confirm approved solutions at 866-704-2384 (BEVI).

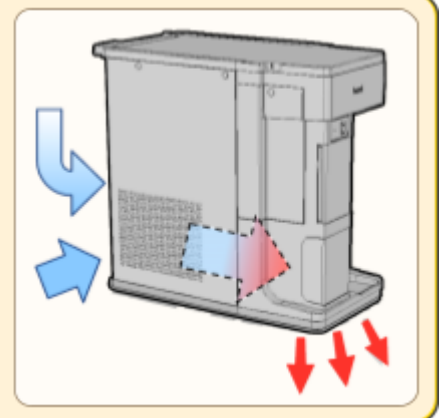

2. Cut Ventilation (Required)

1. If using a 1-1/2" hole saw to drill ventilation holes:
 - a. Use provided Vent Hole Template to mark the center points of the ventilation holes.
 - b. Use the 1-1/2" hole saw to drill the ventilation holes.
2. If using a jigsaw to cut ventilation:
 - a. Use the provided Vent Hole Template to mark drill holes at the corners of the ventilation cutout.
 - b. Use a 1/2" drill to drill the corners of the ventilation cutout.
 - c. Use a jigsaw to make the remaining cuts as indicated on the template.

NOTES:

- *Drill slowly to prevent damaging the underside of the toe kick and to avoid scratching the floors.*
- *Remove cabinet doors for better access and to avoid damaging them.*

Toe Kick
Ventilation

Use cardboard box
to protect floors

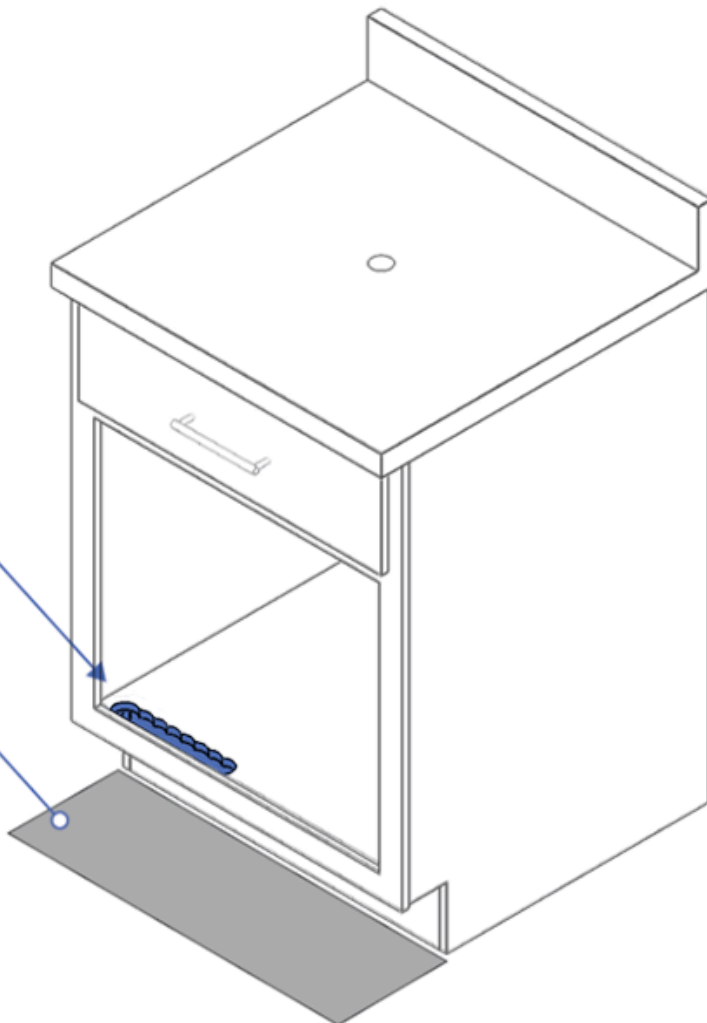

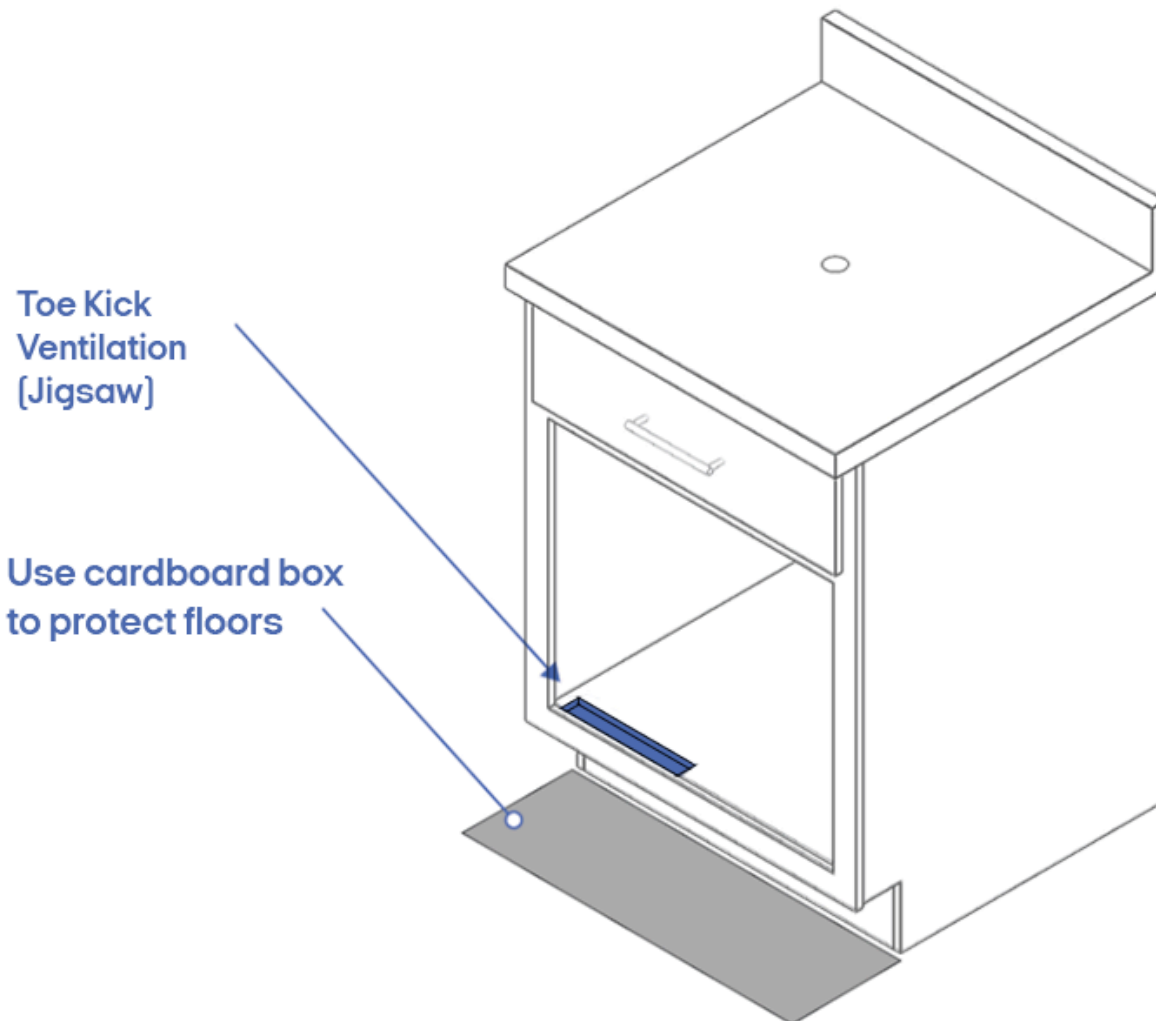

NOTE: Cut slowly to prevent damaging the underside of the toe kick and to avoid scratching the floors. Also, remove cabinet doors for better access and to avoid damaging them.

*** Contact Bevi support for assistance with approved alternative installation methods.**

**** Page left blank for template ****

CHILLER VENT HOLE TEMPLATE (HOLE SAW)

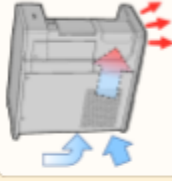

COMPACT CHILLER VENTILATION • **DO NOT** place the compact chiller directly on the cabinet floor!
IMPORTANT: The compact chiller requires its lower ventilation grate to remain clear and properly vented, per the standard installation instructions. The compact chiller will malfunction if its grate is blocked.
Use one of the approved alternative ventilation methods if the cabinet can't support the standard ventilation requirements. Contact Bevi Technical Services to confirm approved solutions at 866-704-2384 (BEVI).

Template Sizing Reference: 1in

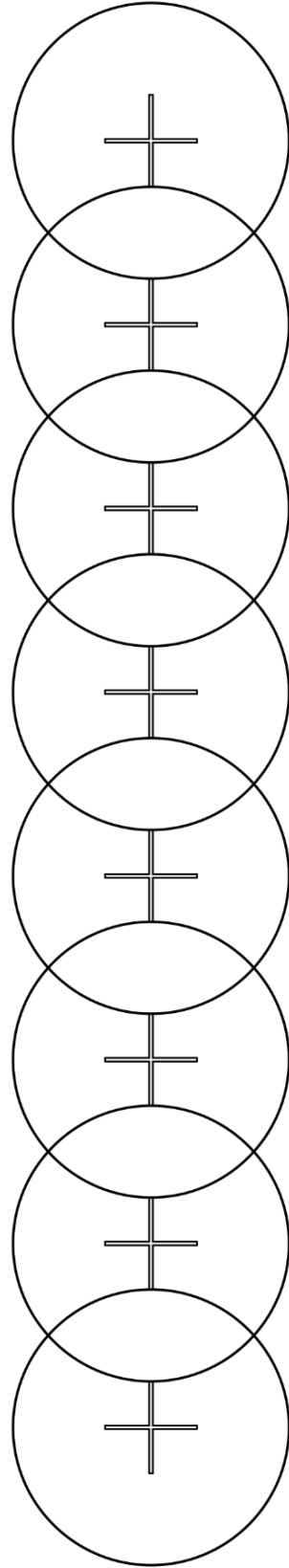

Front of Cabinet

CHILLER VENT HOLE TEMPLATE (JIGSAW)

COMPACT CHILLER VENTILATION • **⚠ DO NOT place the compact chiller directly on the cabinet floor!**
IMPORTANT: The compact chiller requires its lower ventilation grate to remain clear and properly vented, per the standard installation instructions. The compact chiller will malfunction if its grate is blocked.
Use one of the approved *alternative ventilation methods* if the cabinet can't support the standard ventilation requirements. Contact Bevi Technical Services to confirm approved solutions at 866-704-2384 (BEVI).



Template Sizing Reference:  1in

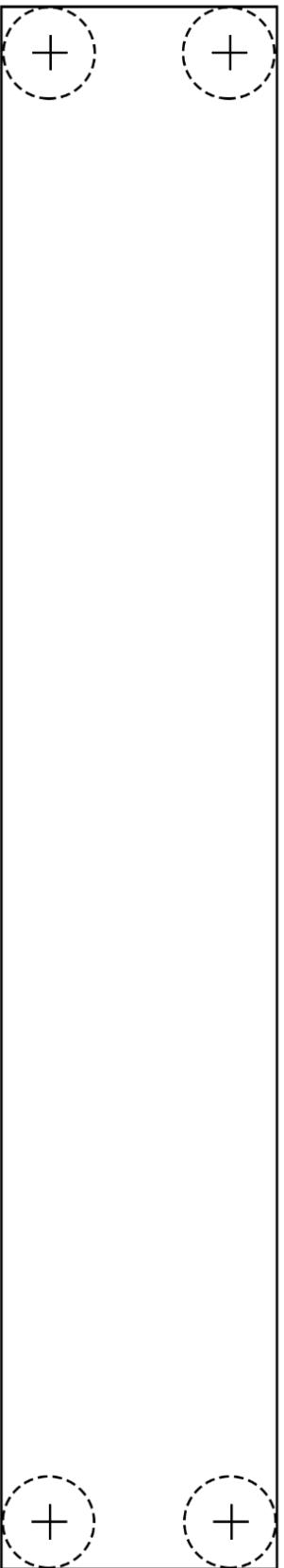

Front of Cabinet

3. CO2 Tank Setup

Ensure the CO2 Tank fits in the desired location prior to installing the strap bracket.

DO NOT OPEN THE CO2 TANK UNTIL INSTRUCTED BY INSTALL WIZARD.

1. Locate the CO2 Pressure Regulator.
2. Connect the CO2 Pressure Regulator to the CO2 Tank with an adjustable wrench. Make sure the gasket is in place between the tank and the CO2 Pressure Regulator.
3. Confirm the CO2 tank fits inside the cabinet with the CO2 pressure regulator attached.

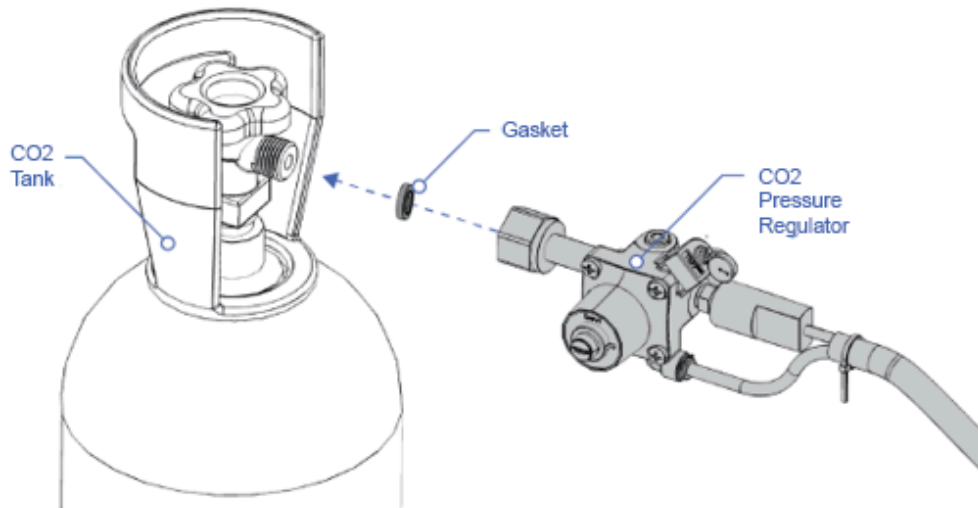

4. Locate the CO2 tank brackets and strap found in the “Hardware” bag, and select an interior cabinet wall for mounting the Strap Bracket (shown below).

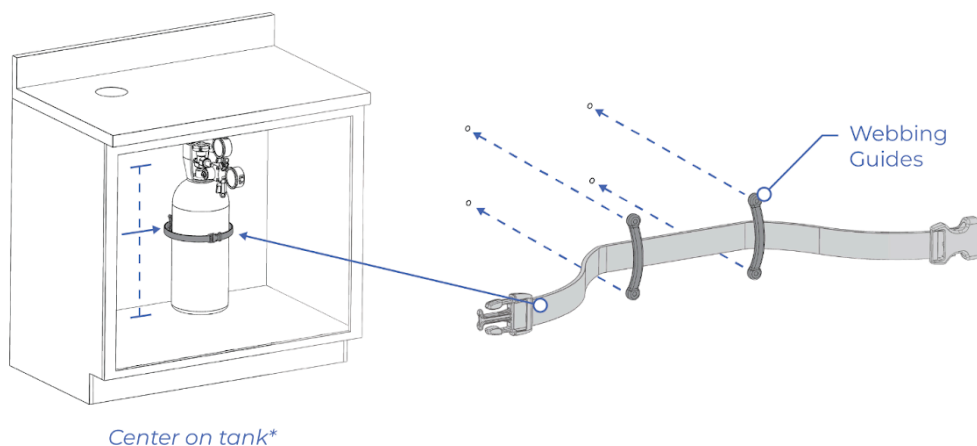

5. Drill 1/16” pilot holes according to the template **on the next page** and secure brackets with provided #8 wood screws.
6. Secure the CO2 tank in place by ensuring the strap wraps around the center of the tank and is clipped in.

**** Page left blank for template ****

CO2 Tank Strap Bracket Template

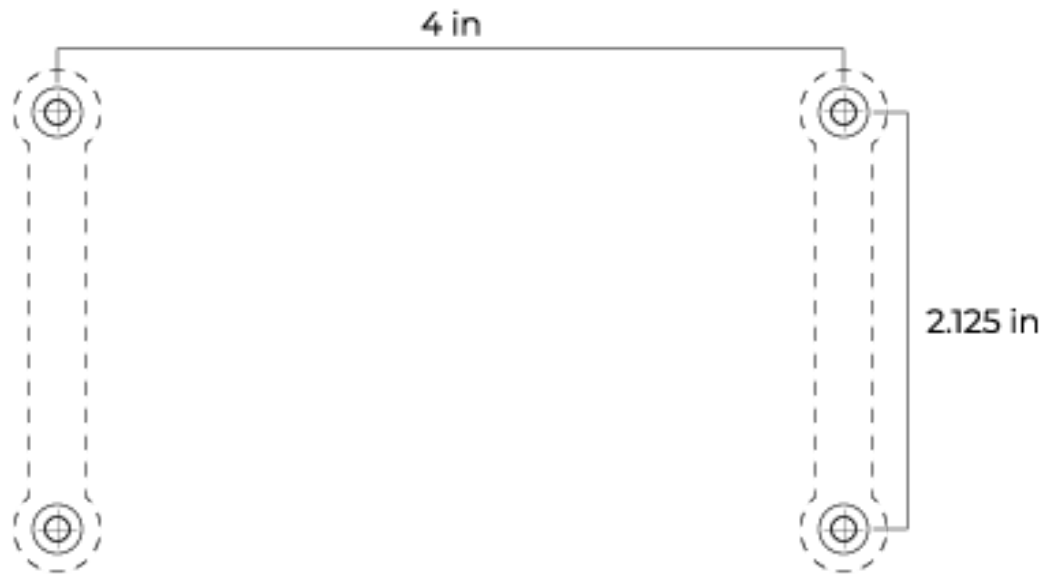

1. Cut off and tape this template in the desired location.
2. Ensure that it is mounted at the proper height so that the strap wraps safely around the CO2 tank. Recommended mounting height is 12" for 5 and 10 lb CO2 tanks (about the height of this sheet of letter-sized paper) and 16" for 20 lb CO2 tanks.
3. Drill 1/16" pilot holes for the 4 mounting holes.
4. Use the provided #8 wood screws to install the brackets.

**** Page left blank for template ****

4. Clean Countertop and Cabinets

Ensure the countertop surface and cabinets are clean before installing the Chiller and the Head Unit.

Vacuum or sweep the inside of the cabinets and floor after drilling ventilation holes and mounting points. This ensures no dust or debris gets into the machinery.

Sand or debur the countertop hole if necessary to make sure the Head Unit is installed on a clean and flat surface. Clean off the countertop surface to ensure a good seal with the bottom of the Head Unit. This helps prevent water from flowing into the cabinet below.

****Clean before installing machine****

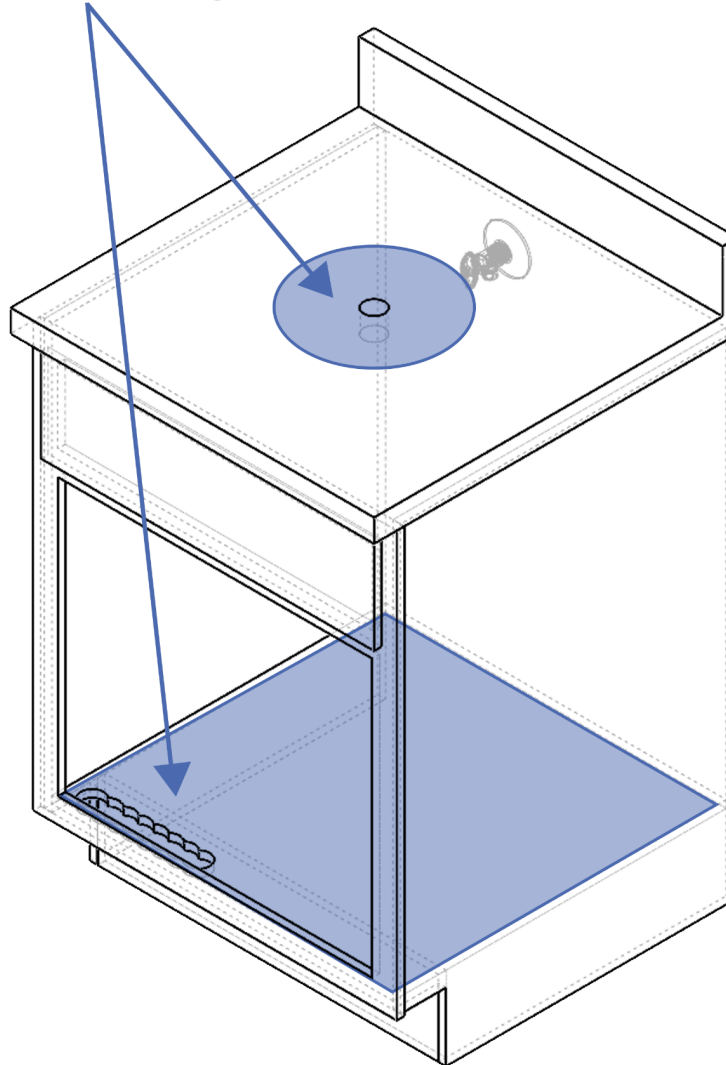

5. Head Unit Setup

Ensure all cables and tubing can reach their corresponding components prior to securing the Head Unit to the countertop.

1. If the countertop hole is already drilled, confirm the size of the hole and configuration. For hole sizes larger than 1-1/4", the adapter plate (included in drip tray packaging) will be required to seal the remaining hole area.
 - a. 1-1/4" hole (smallest acceptable hole size)
 - b. 2" hole (requires adapter plate)
 - c. 4" hole (requires adapter plate, largest acceptable hole size)
 - d. Larger than 4" (please contact Bevi Support at support@bevi.co or 866-704-BEVI)
2. If power outlets are available **above the counter**, proceed to the next numbered step. If power is provided *below* the counter, do the following steps first:
 - a. Push the power cable through the grommet on the rear of the back panel until the cable is completely inside the head unit. This hides the unused power cable.
 - b. Power the compact chiller using a separate power cable, provided separately as a field replaceable part (FRU P/N #720-0339). Please reach out to Bevi Support at support@bevi.co for ordering.
3. Prepare to place the Head Unit over the countertop hole. The Head Unit can be placed on its side to feed the trunkline and cables through the countertop hole.
 - a. If the Head Unit with threaded coupler does not fit beneath shelves or cabinets (i.e. less than 22" vertical distance from countertop surface to cabinets), remove the threaded coupler by unscrewing it from the base of the Head Unit, and slide it 12–18" down the trunkline.

NOTE: Threads on the coupler are sharp, gloves or cloth are recommended.
4. Feed the trunkline tubing and cables (and coupler, if removed) through the countertop hole.
 - a. First, feed the AC power cable through.
 - b. Then feed ethernet cable, communications cable, and DC power cable through.
 - c. Finally, feed flavor lines and insulated water lines (trunkline) through.
5. Lift the Head Unit upright and place in its intended position as shown below. We recommend picking up the Head Unit with one arm, and using the other arm to feed the last 4-6" of trunkline through the countertop hole (see illustration below)
 - a. **If threaded coupler is still attached:** Guide the threaded coupler through the countertop hole so it is beneath the countertop surface.
 - b. **If threaded coupler was removed:** Slide up and reinstall the threaded coupler into the base of the Head Unit from beneath the countertop surface. **NOTE: Threads on the coupler are sharp, gloves or cloth are recommended.**

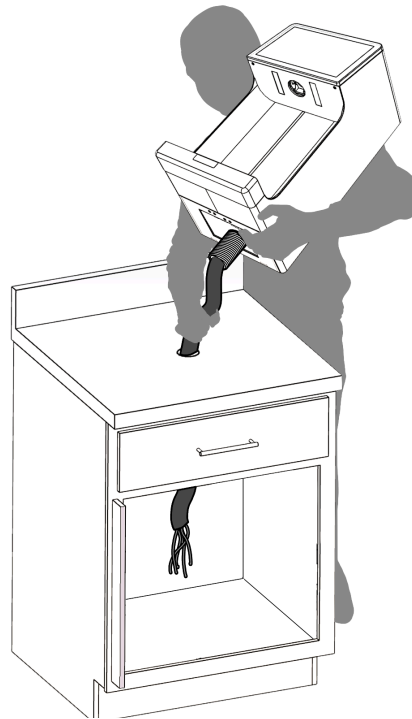

6. If the hole size requires the adapter plate, thread the trunkline from the head unit through the adapter plate, and ensure that it sits flush to the underside of the countertop surface when installed.
7. Secure the Head Unit to the countertop from below with the M32 **split nut** (included with Head Unit). To ensure a proper seal, pull down on the threaded coupler and use the other hand to tighten the nut. If you have difficulty closing the split nut on top of the threaded coupler, close it below the coupler so that it snaps closed, and then thread it onto the coupler from below.
 - a. The M32 split nut can be ordered as a field replaceable part (FRU P/N #720-0338) if it is broken or misplaced. Please reach out to Bevi Support at support@bevi.co for ordering.
8. Confirm the Head Unit is square with the front of the countertop surface. Measure the distance from the left and right sides of the head unit to the front of the countertop surface – these distances should be the same.
9. Remove the drip tray from packaging and install beneath the nozzle of the Head Unit.

6. Chiller Setup

FRONT VIEW OF CHILLER

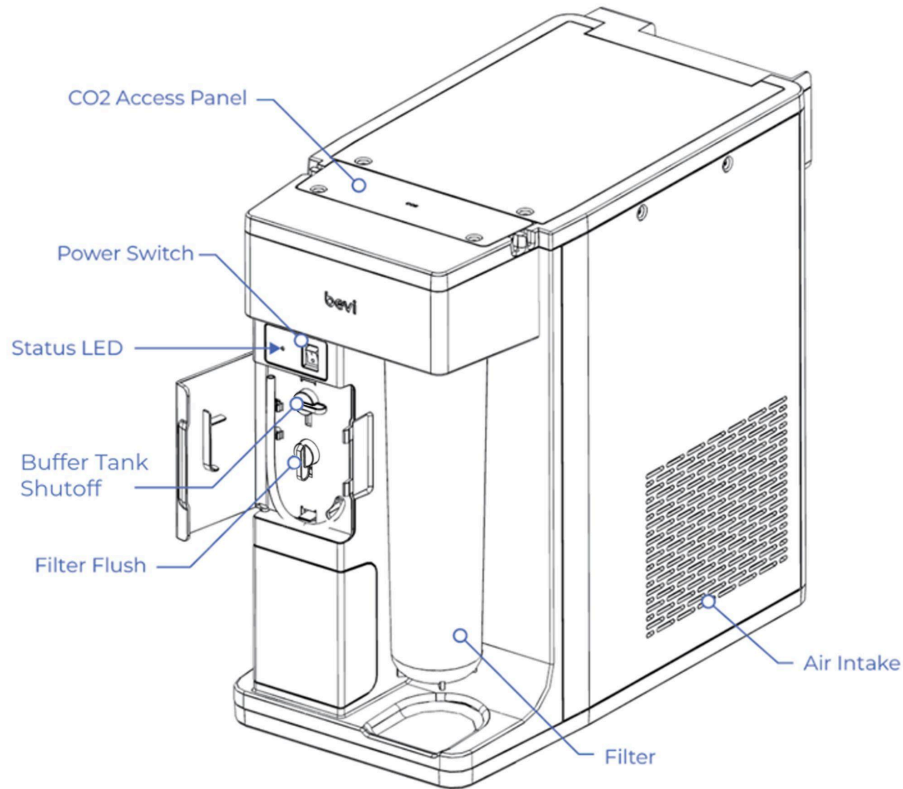

REAR VIEW OF CHILLER

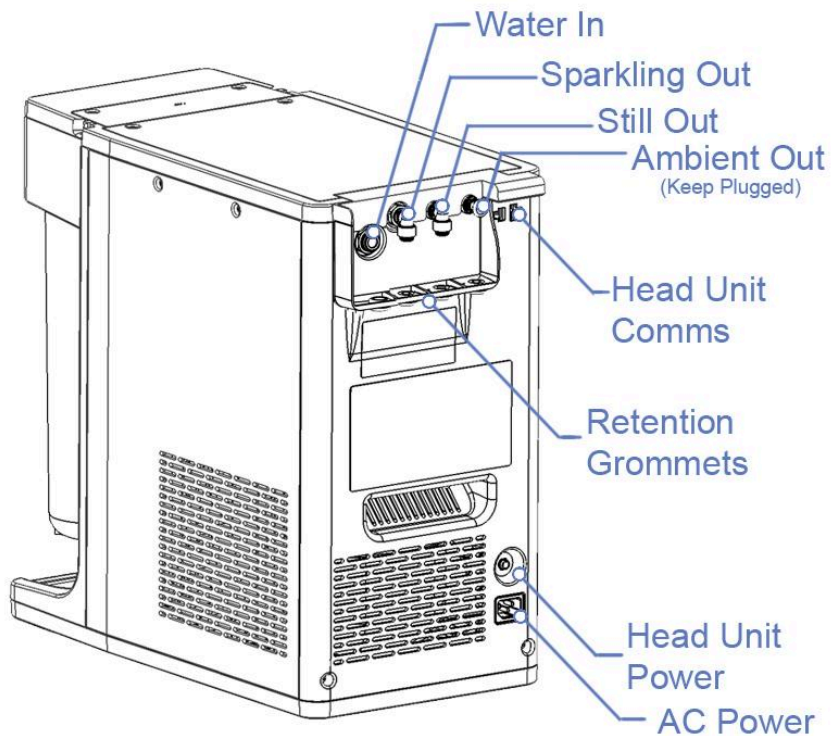

REAR VIEW OF CHILLER

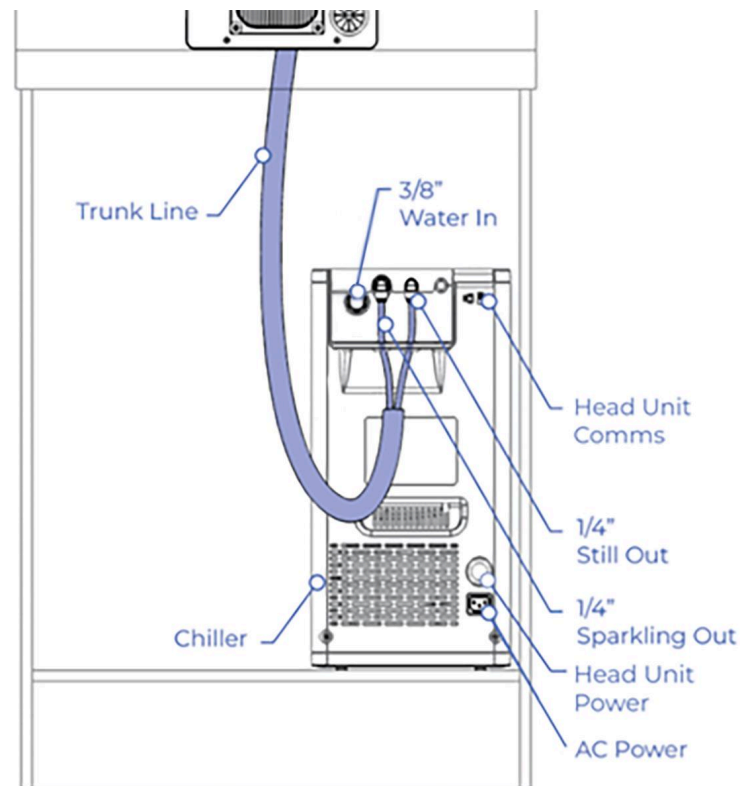

BEFORE INSTALLING CHILLER

- **DO NOT** turn on water or CO2 until instructed to do so in the on-screen Installation Wizard.
- **DO NOT** turn on power to the Chiller until all power, data, and water connections are complete.
- **DO NOT** disconnect power, data, or water connections unless the chiller is fully powered OFF.
- **Ensure** Ambient Out connector is plugged.
- Ensure all lines are **fully pushed in**, or water will leak. Double-check!

Chiller Upright Storage Requirements

The Compact Chiller can be turned on immediately if shipped upright. If it was *not* shipped upright, it should be stored in an upright position for at least 24 hours before powered on.

1. Place the chiller in front of the cabinet.
2. While the chiller is still outside and in front of the cabinet, install cables and water lines at the back of the chiller. Ensure the water lines are cut to a length that allows the chiller to be positioned outside of the cabinet before moving it into the cabinet.
 - a. Ensure the tube has a clean and square cut, and is free of scratches or marks.

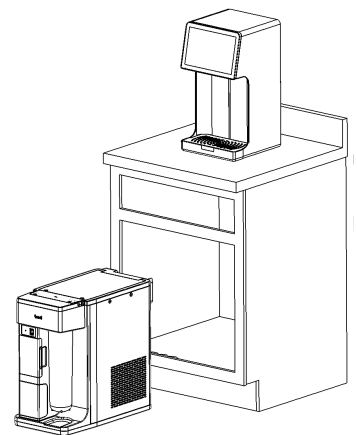

3. Complete all connections:

- a. Install the **3/8" Water source line and elbow fitting** into the back of the chiller

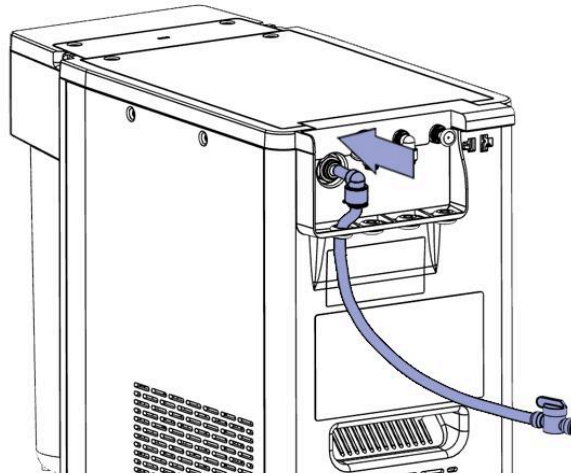

- b. Install water line from the installation site, to the shutoff valve.
NOTE: Flush the supply water line until it is completely free of debris, before connecting to the chiller.
- c. Install the **1/4" Still** and **Sparkling lines** from the Head Unit into the back of the chiller.
- Confirm it is placed through the black retention grommet, and fully secured into the corresponding Push To Connect (PTC) fitting.
- d. **Ensure that all water lines are fully seated in the fittings.** A leak may occur if they are not fully seated before turning the machine on.
- e. Connect the Head Unit's Power and Communication cables to the back of the chiller.
- f. Plug the AC Power Cord into the back of the chiller.
- g. Plug the AC Power Cord above the counter into a wall outlet to power on the Chiller and Head Unit.

4. Remove the CO2 Access Panel

- a. Loosen 2x captive Philips screws, and lift up on panel

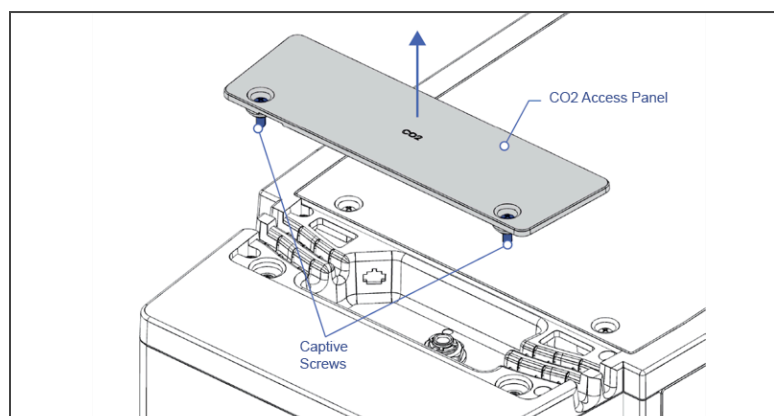

Route the 1/4" tubing + sensor cable from the CO2 Pressure Regulator into below the access panel. The tube and sensor cable can be routed from either side of the chiller.

- b. Connect the 1/4" tubing to the PTC fitting.
- c. Connect the sensor cable. **Ensure connector latch is facing upward**

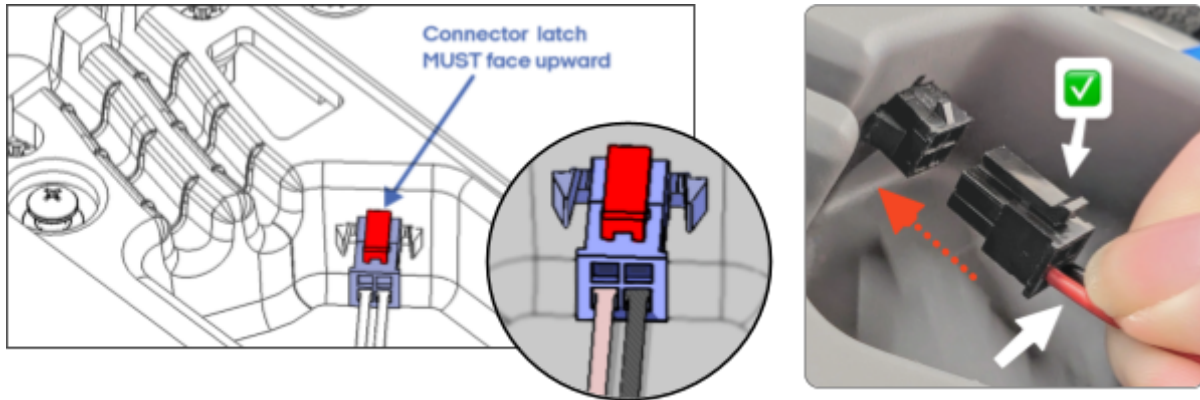

- d. Replace the CO2 panel using PH02 screwdriver.

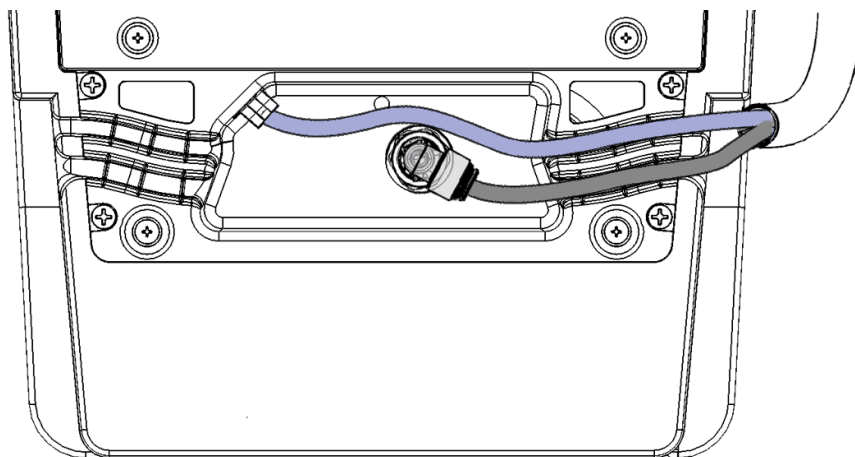

5. Confirm all push-to-connect (PTC) fittings are fully inserted and secured with a locking clip after the tubes are inserted.

- a. Check that the locking clips are secured around each PTC collet.

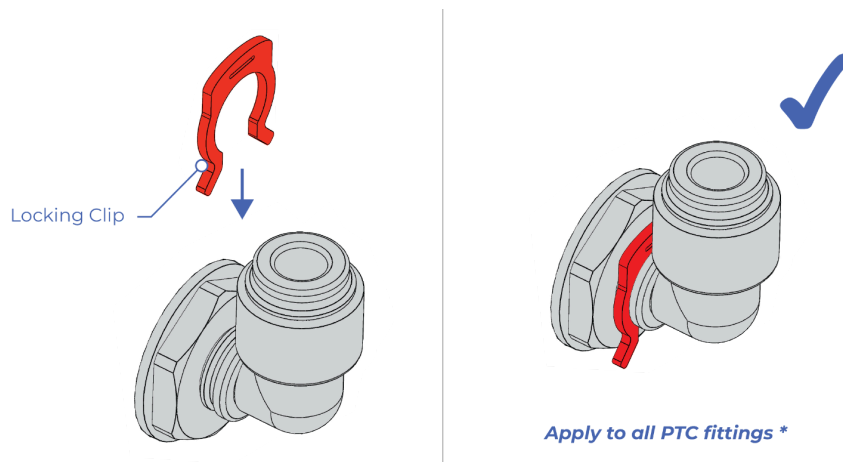

Place the Chiller inside the cabinet.

- b. Ensure the chiller is in position, **fully aligned** with the venting holes (see below).
- c. Confirm the chiller is resting flat against the cabinet base, with the rolled retaining features on the underside of the metal ventilation grate seated inside the cabinet's ventilation holes.
- d. ** If ventilation grate was installed upside-down, without retaining features facing downward:* Remove the grate by inserting your thumb into the half-moon cutout at the front-center of the grate, press the grate toward the back of the chiller, then pull it down and out (image below). Flip the grate so the rolled retaining features face downward. *To reinstall:* Align the four sheet metal tabs with the four slots on the bottom of the chiller, press the grate towards the back, and rotate it upward until it catches into place by the two front-edge shelves.
- e. ** If the grate is dislodged and falls out of the machine:* Reinstall it with the rolled retaining features facing downwards to lock in to the ventilation holes.

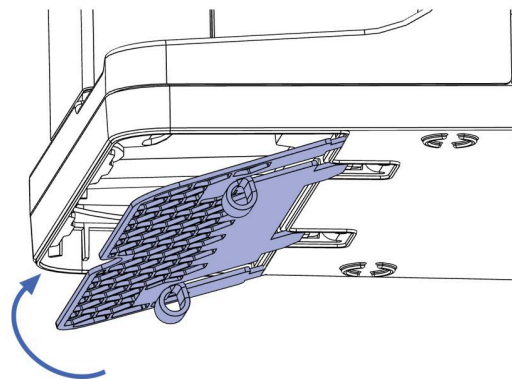
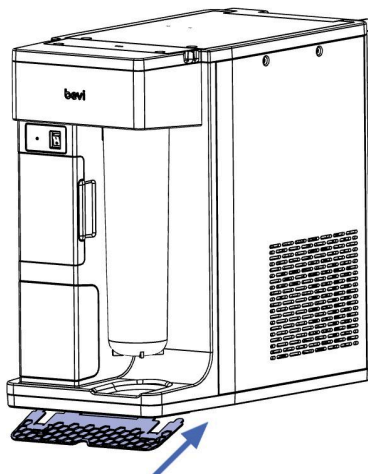
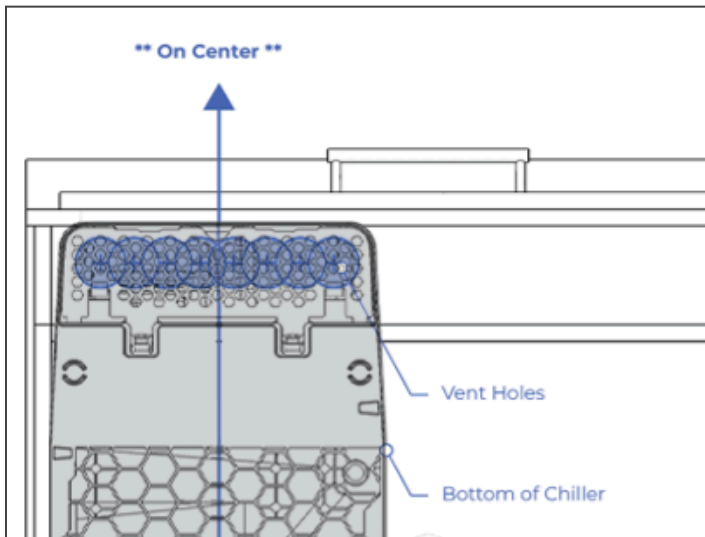

6. **DO NOT turn on source water or open the supply water valve.** This will be completed while progressing through the on-screen Install Wizard.

7. Flavor Setup

1. Install all Flavor Connectors, 4 in total, onto the flavor lines coming from the Head Unit.

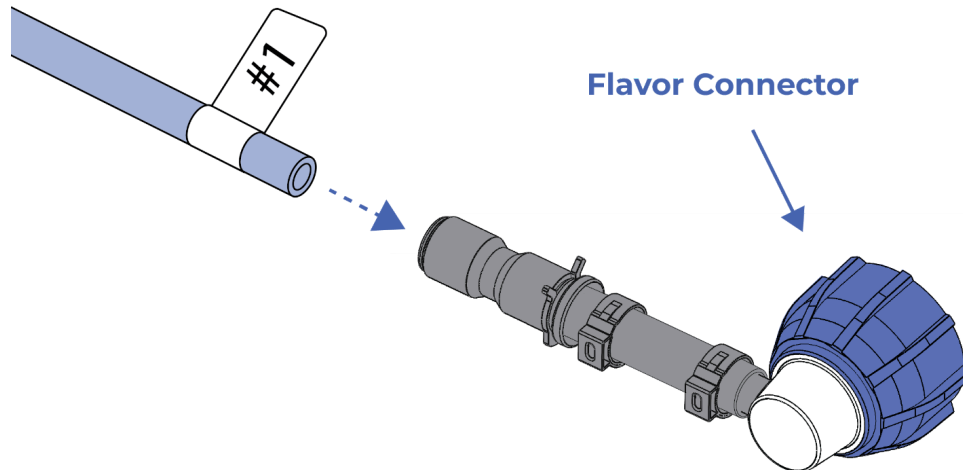

2. Install locking clips on the fittings of the flavor lines and connectors.
3. Screw each Connector to a Flavor Box by rotating the Connector clockwise.
 - a. Ensure the Connector is fully seated and not leaking.
 - b. Improper alignment can inhibit flavor from dispensing properly.

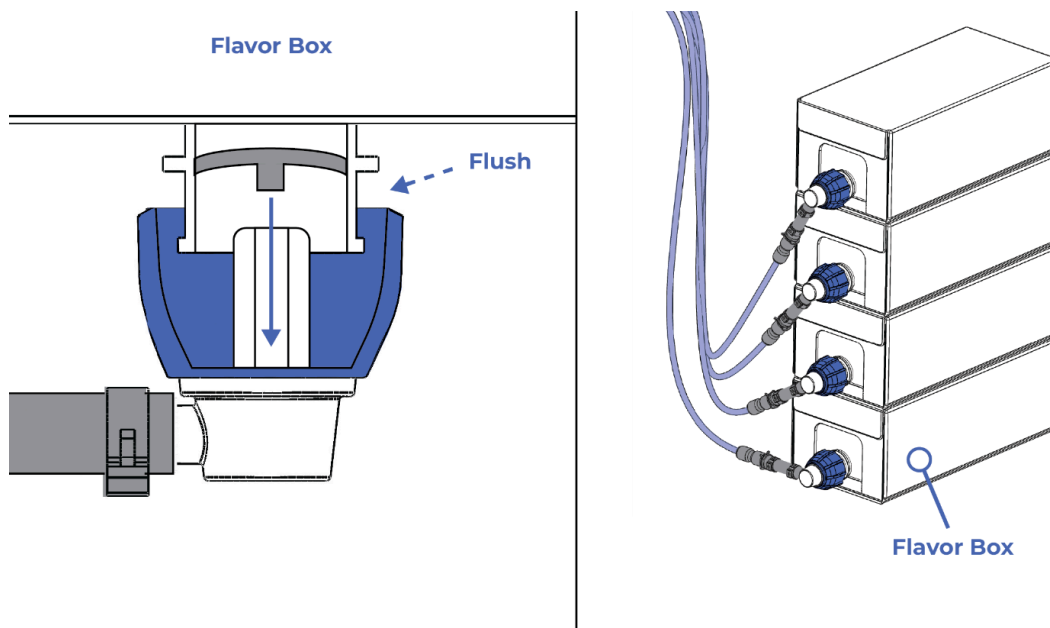

4. Ensure each Flavor Box is properly installed in the cabinet.
 - a. **DO NOT** position flavor boxes so that they are standing up.
 - b. **DO NOT** prop flavor boxes up on other items in the cabinet.
 - c. **DO NOT** place other items in the cabinet, e. g. cleaning supplies or food.

8. Complete Setup on Screen

Proceed to follow all on-screen instructions before finishing the installation.

1. Locate the power switch on the front of the chiller and turn it on. **DO NOT** turn on water or CO2 until instructed to do so in the on-screen Installation Wizard.
2. Remove protective film on the touchscreen.
3. Follow the on-screen Installation Wizard.

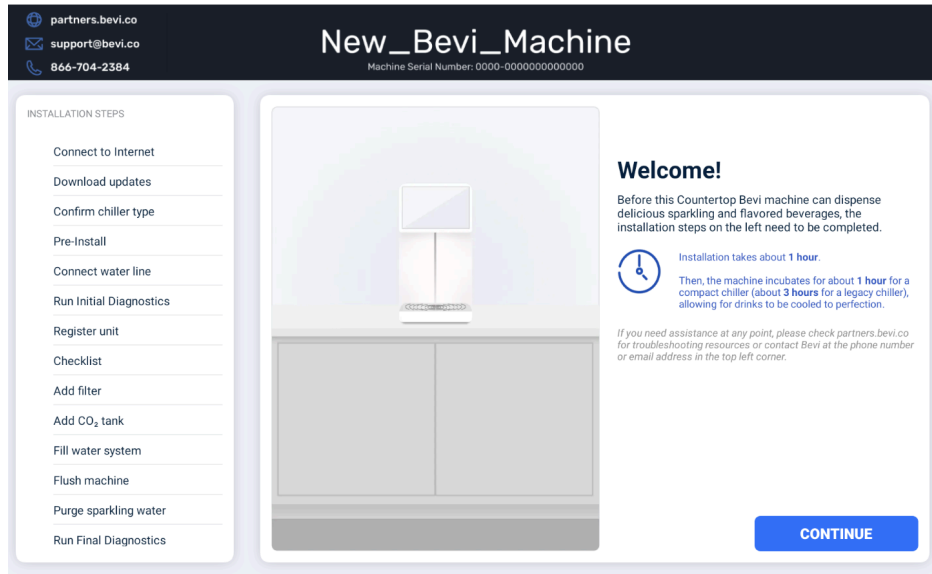

4. Stock the machine with the flavors that were just installed.
 - a. For Flavor 1, select the “Restock” button.

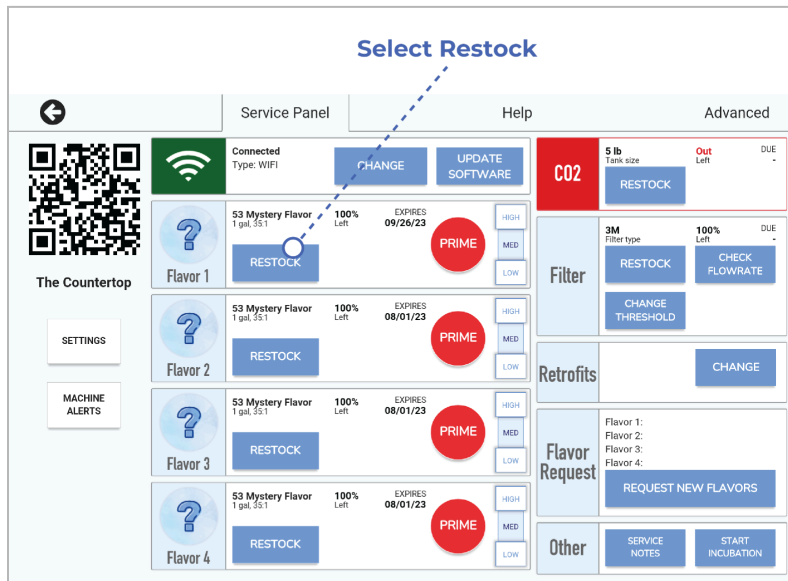

- b. Input the Flavor and the Best By Date from the corresponding Flavor Box.
 - i. Confirm the Flavor number on screen matches the label on the Flavor Connector.

c. Select Confirm.

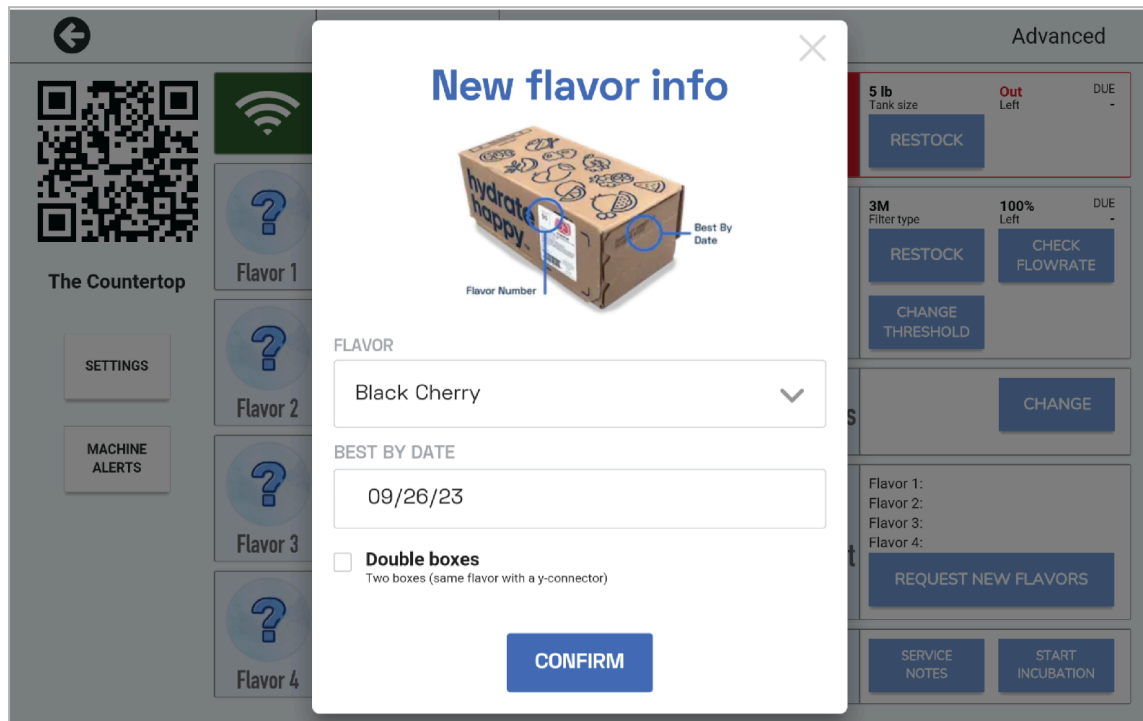

5. Repeat for the remaining flavors.

6. Once all flavors are stocked, proceed to Prime each flavor.

a. Place a bucket or wide-mouth bottle under the nozzle to capture the primed flavors.

7. Exit the service panel by selecting the arrow in the top left corner.

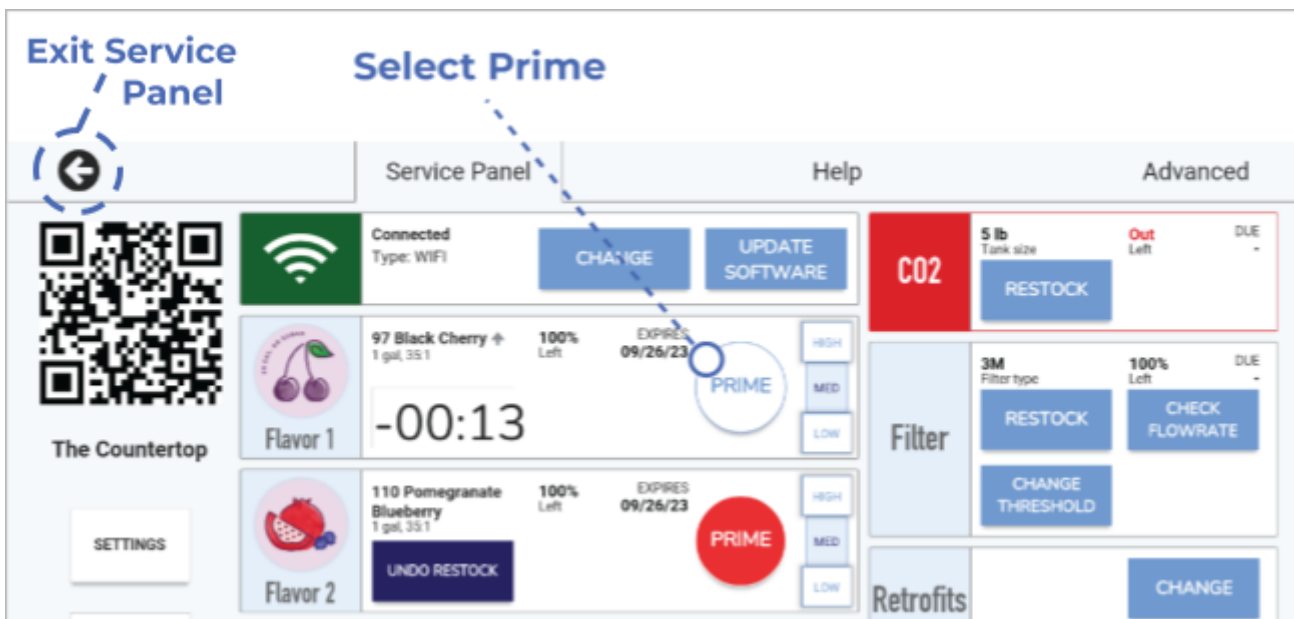

9. Before You Leave

Give an overview of the machine and demonstrate how to dispense a beverage.

1. Show all **shutoff valve(s)** to the customer.
2. Show the **location of the power switch** to the customer on the Chiller.
3. Give the customer an overview of the machine.
 - a. Repeatedly tap the word “**Just**” to access the Demonstration Mode.

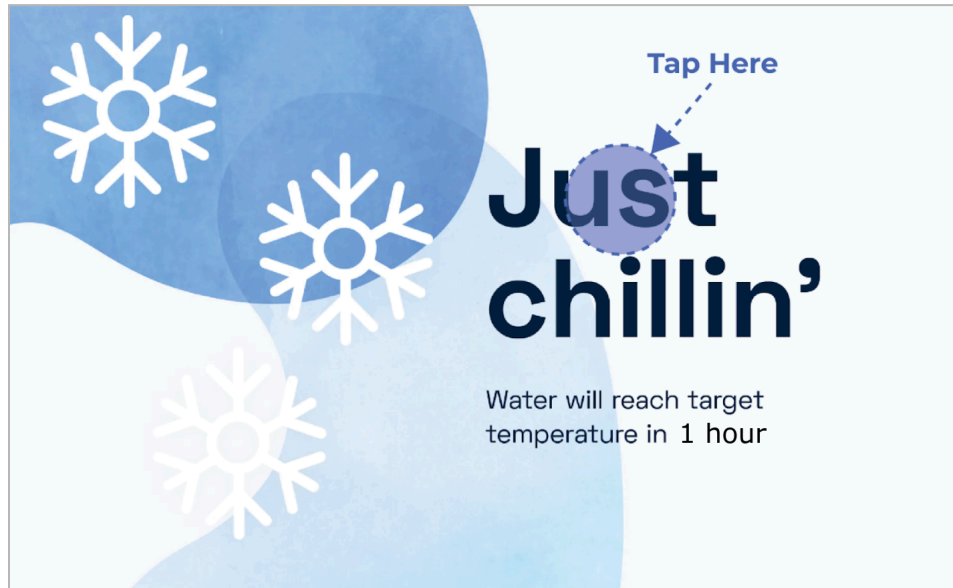

4. **Demonstrate** how to dispense a beverage.
 - a. Show how to select multiple flavors, and show how flavor strength can be adjusted.
 - b. Explain that only 3 flavors can be selected at a time.
 - c. Show how to select and dispense **Still** vs. **Sparkling** beverages.



Congratulations!

You just installed a new
Countertop 1.5!

Please visit partners.bevi.co for any additional
machine information.

We are happy to answer your questions at
support@bevi.co or [1-\(866\)704-2384](tel:1-866-704-2384)

TEAR-AWAY TEMPLATES

Head Unit Countertop Hole Template

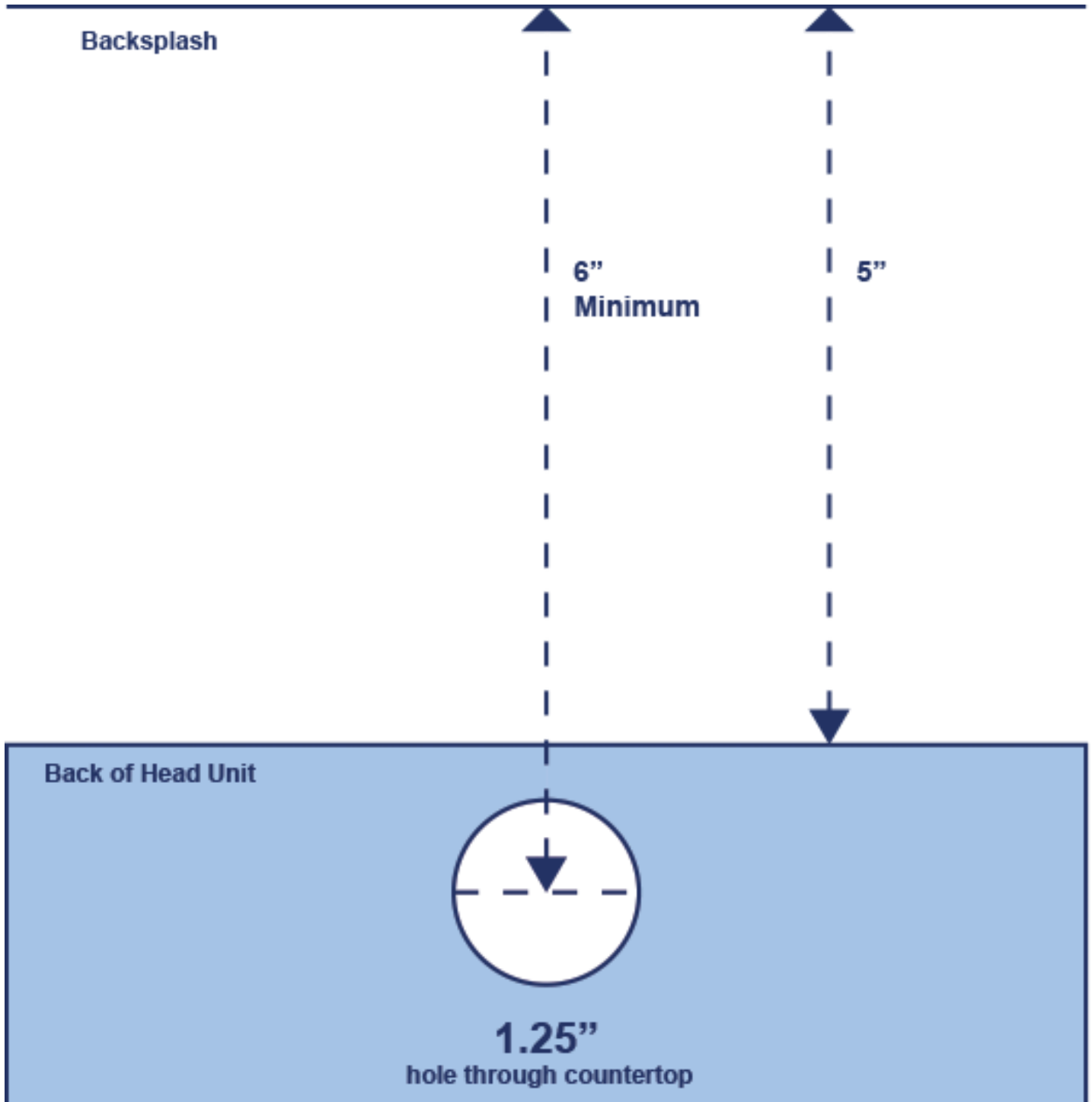

**** Page left blank for template ****

CHILLER VENT HOLE TEMPLATE (HOLE SAW)

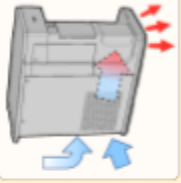

COMPACT CHILLER VENTILATION • **⚠ DO NOT** place the compact chiller directly on the cabinet floor!
IMPORTANT: The compact chiller requires its lower ventilation grate to remain clear and properly vented, per the standard installation instructions. The compact chiller will malfunction if its grate is blocked.
Use one of the approved *alternative ventilation methods* if the cabinet can't support the standard ventilation requirements. Contact Bevi Technical Services to confirm approved solutions at 866-704-2384 (BEVI).

Template Sizing Reference: 1in

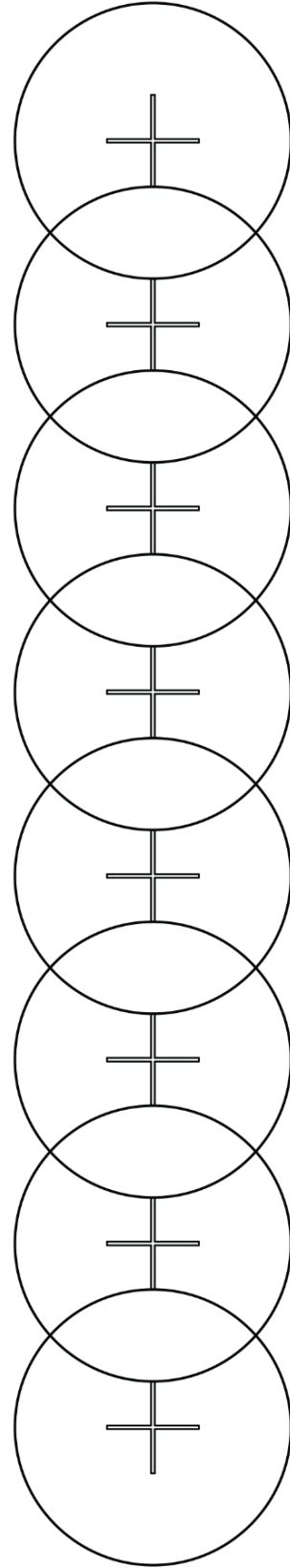

Front of Cabinet

CHILLER VENT HOLE TEMPLATE (JIGSAW)

COMPACT CHILLER VENTILATION • **⚠ DO NOT place the compact chiller directly on the cabinet floor!**
IMPORTANT: The compact chiller requires its lower ventilation grate to remain clear and properly vented, per the standard installation instructions. The compact chiller will malfunction if its grate is blocked.
Use one of the approved *alternative ventilation methods* if the cabinet can't support the standard ventilation requirements. Contact Bevi Technical Services to confirm approved solutions at 866-704-2384 (BEVI).



Template Sizing Reference:  1in

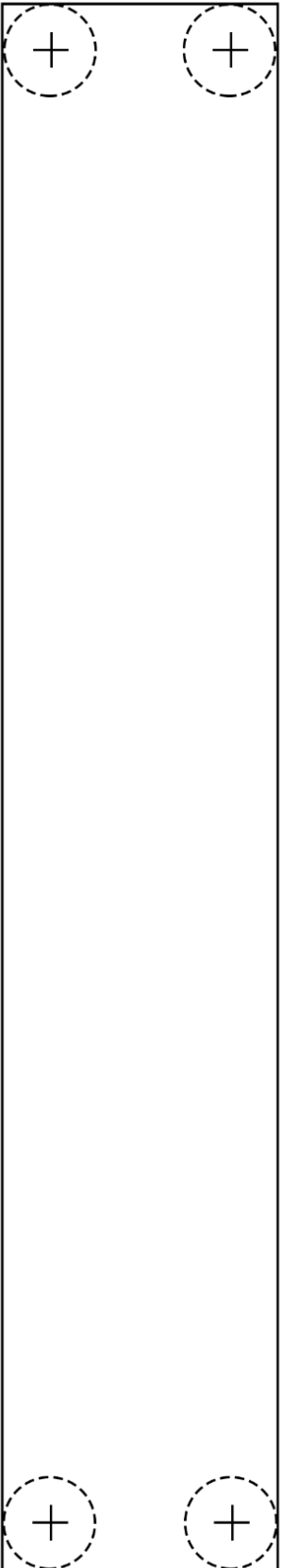

CO2 Tank Strap Bracket Template

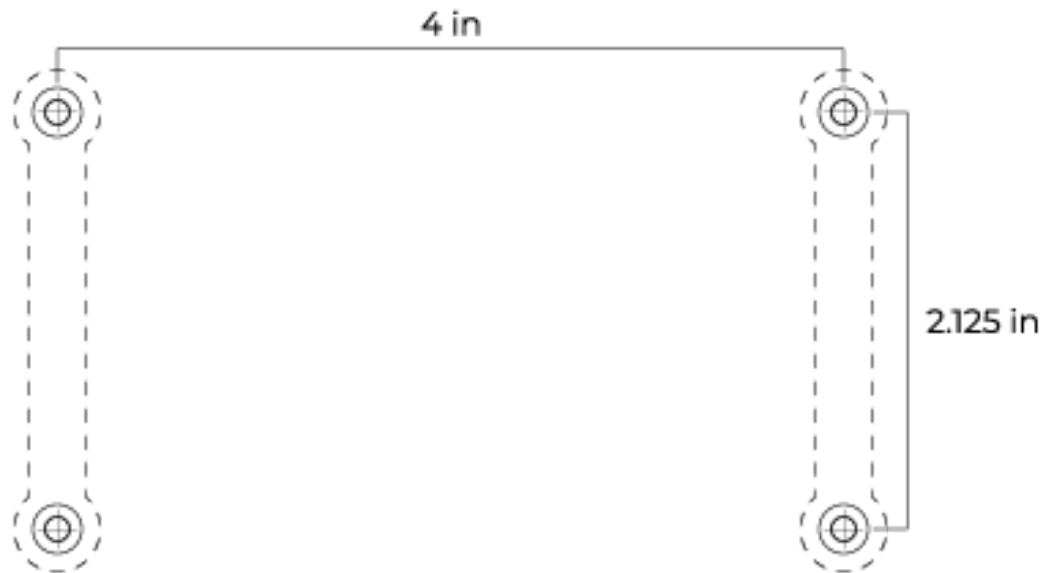

5. Cut off and tape this template in the desired location.
6. Ensure that it is mounted at the proper height so that the strap wraps safely around the CO2 tank. Recommended mounting height is 12" for 5 and 10 lb CO2 tanks (about the height of this sheet of letter-sized paper) and 16" for 20 lb CO2 tanks.
7. Drill 1/16" pilot holes for the 4 mounting holes.
Use the provided #8 wood screws to install the brackets.

**** Page left blank for template ****